

EN	RADIATOR RELOCATION KIT WITH SNORKEL KIT INSTALLATION MANUAL
DE	SCHNORCHEL EINBAU - UND MONTAGEANLEITUNG
RU	ИНСТРУКЦИЯ ПО УСТАНОВКЕ ВЫНОСА РАДИАТОРА С КОМПЛЕКТОМ ШНОРКЕЛЕЙ

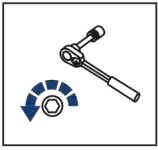

**For: RM 800 (2016-2018)
RM 800 DUO (2019-)**

444.7747.1



EN Regular fasteners
DE Originale montageteile
RU Штатный крепеж

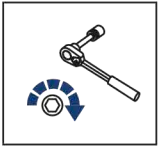

EN Regular fasteners
DE Originale montageteile
RU Штатный крепеж



EN Screw a several turns
DE Für wenigen Umdrehungen befestigen
RU Вкрутить на несколько оборотов



EN Loosen bolts
DE Bolzen lockern
RU Выкрутить на несколько оборотов

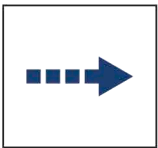



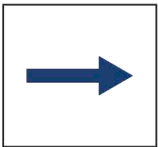













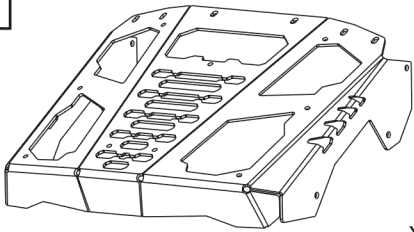
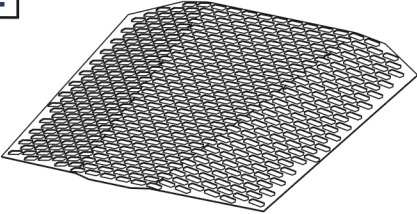
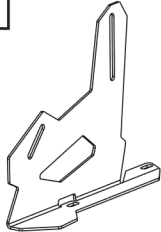
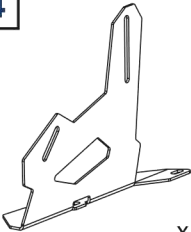
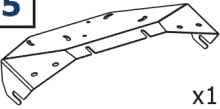
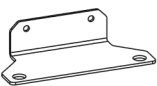
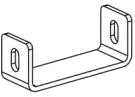
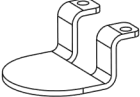
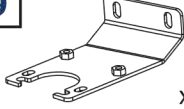
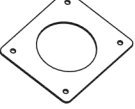

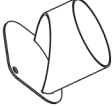
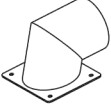













EN Movement Arrow
DE Bewegungsrichtung
RU Движение



EN Location/Position Arrow
DE Anordnung/Positionsrichtung
RU Расположение



EN Screw Arrow
DE Drehungsrichtung
RU Поворот

 EN Ratchet DE Ratsche RU Трещётка		 S - 7 S - 10 S - 13		 HEX S - 4		 EN Drill DE Bohrmaschine RU Дрель		 $\varnothing 70$ $\varnothing 80$		 $\varnothing 4$		 EN Crosshead Screwdriver DE Kreuzschlitz-Schraubendreher RU Отвёртка крестовая	
1  x1			2  x1			3  x1		4  x1					
5  x1		6  x1		7  x2		8  x1		9  x1		10  x1			
11  x2		12  x1		13  x1		14  $\varnothing 6\text{mm}$; L=1m x1		15  $\varnothing 20\text{mm}$; L=1.5m x1		16  $\varnothing 20\text{mm}$ x1			
17  L=0.9m; $\varnothing 63$ x1		18  L=1.6m; $\varnothing 63$ x1		19  L=1.25m; $\varnothing 73$ x1		20  10-16 x2		21  20-32 x4		22  60-80 x4			
23  x2		24  x4		25  M4x12 x4		26  M6x16 x19		27  M6x20 x8		28  M6x35 x4			
29  M8x20 x4		30  $\varnothing 4$ x8		31  $\varnothing 6$ x8		32  $\varnothing 6$ x48		33  $\varnothing 8$ x8		34  M4 x4			
35  M6 x25		36  M8 x4											

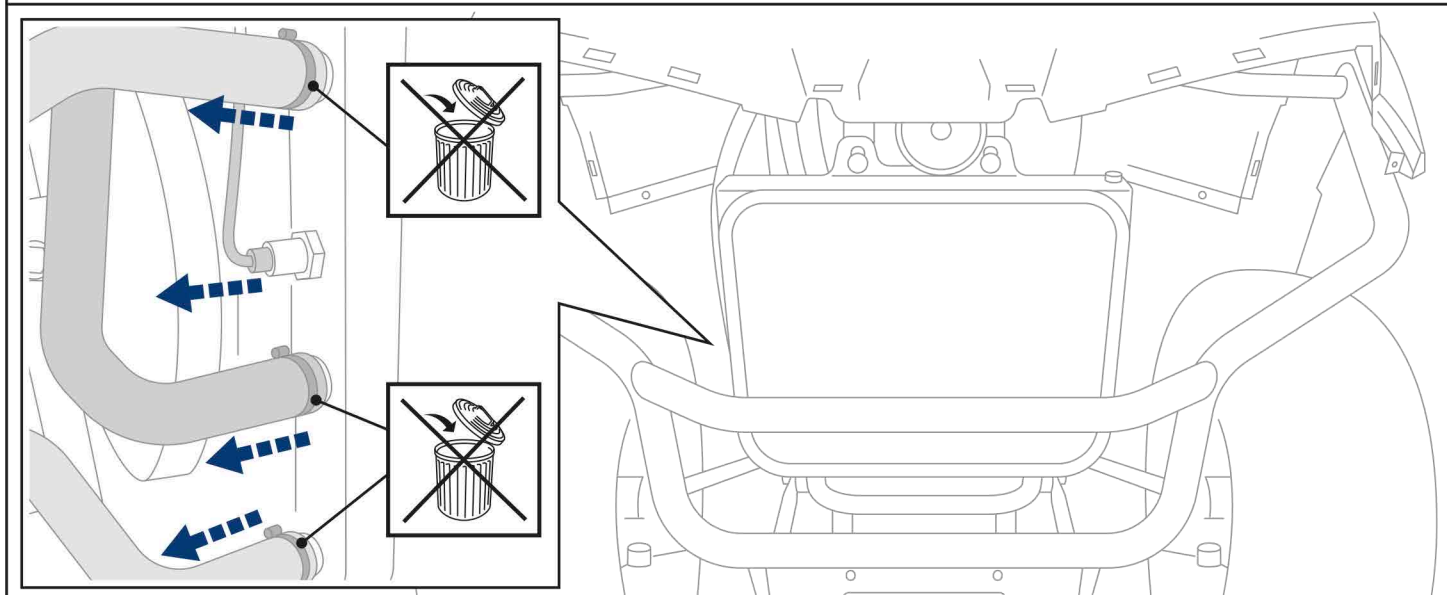
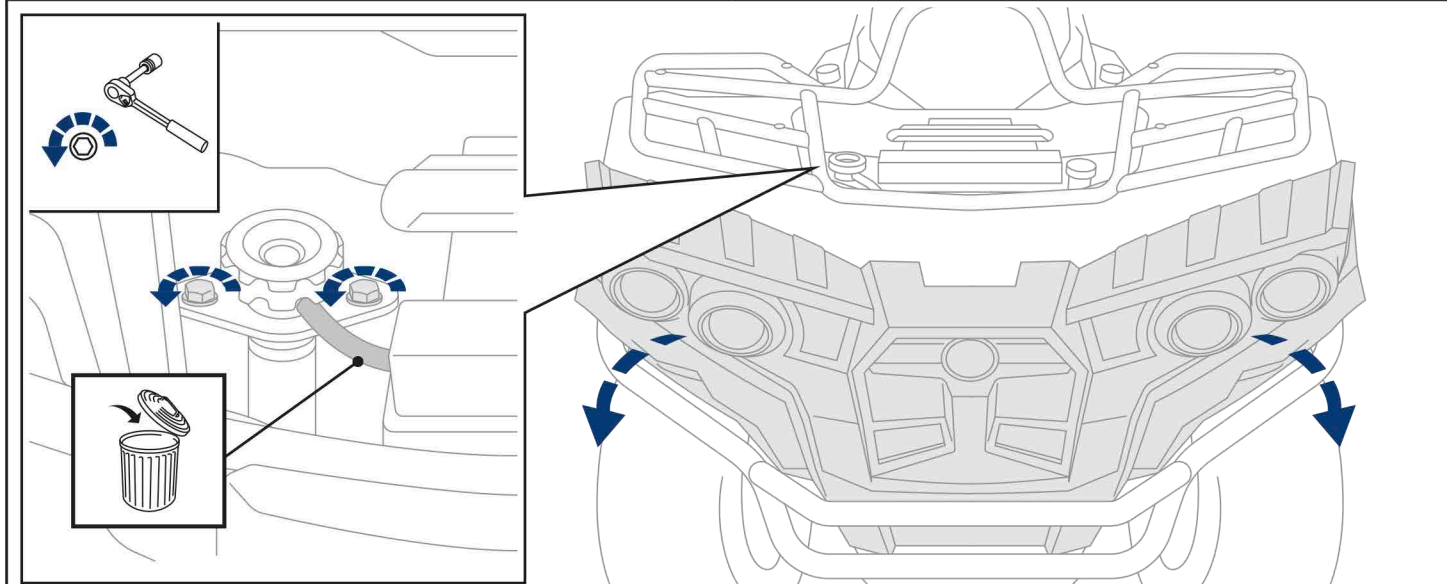
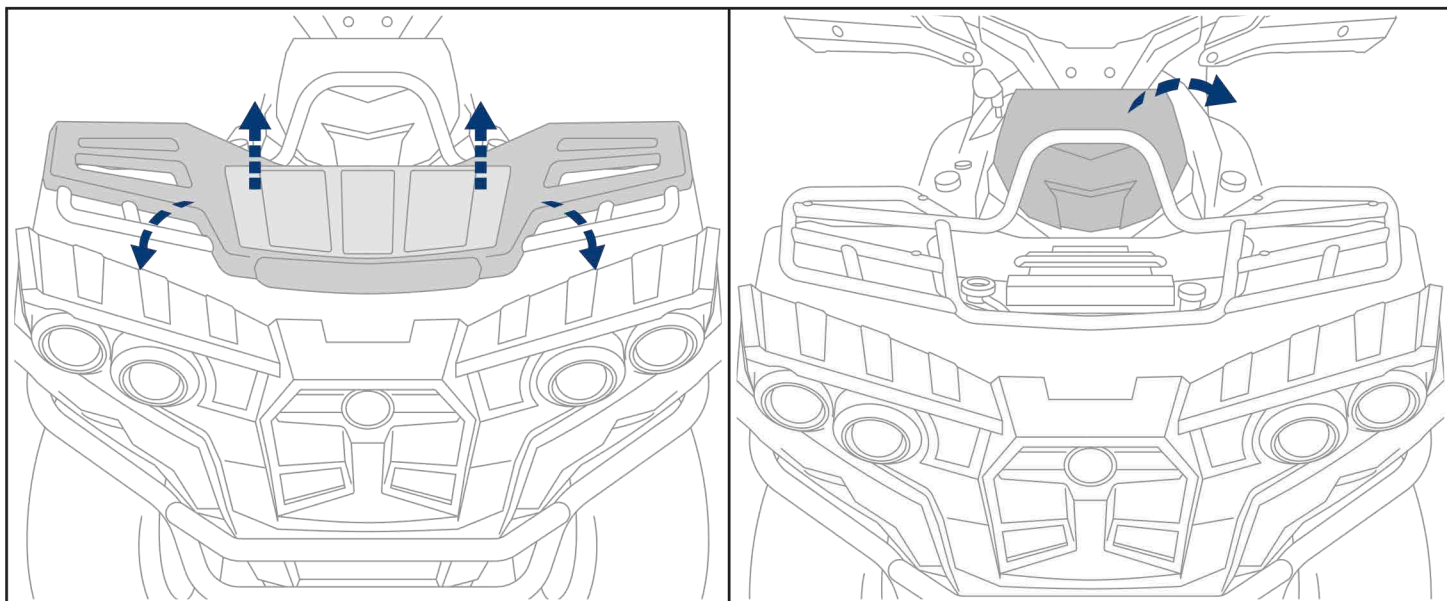

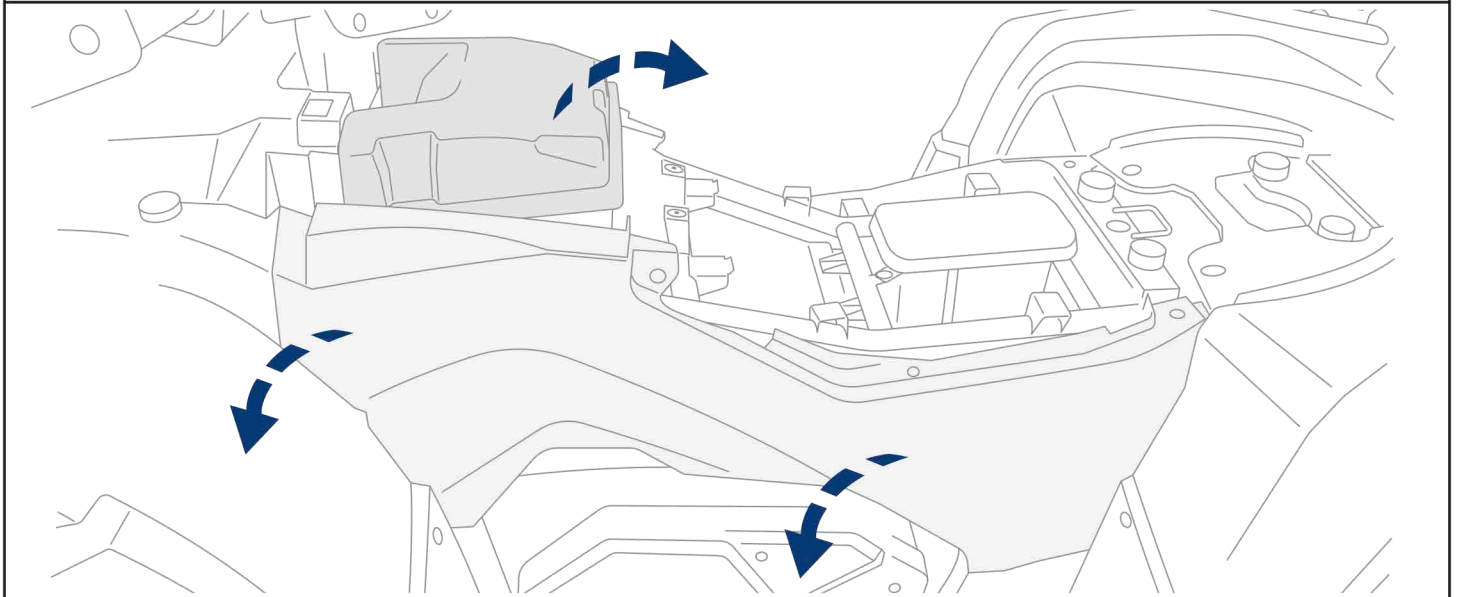
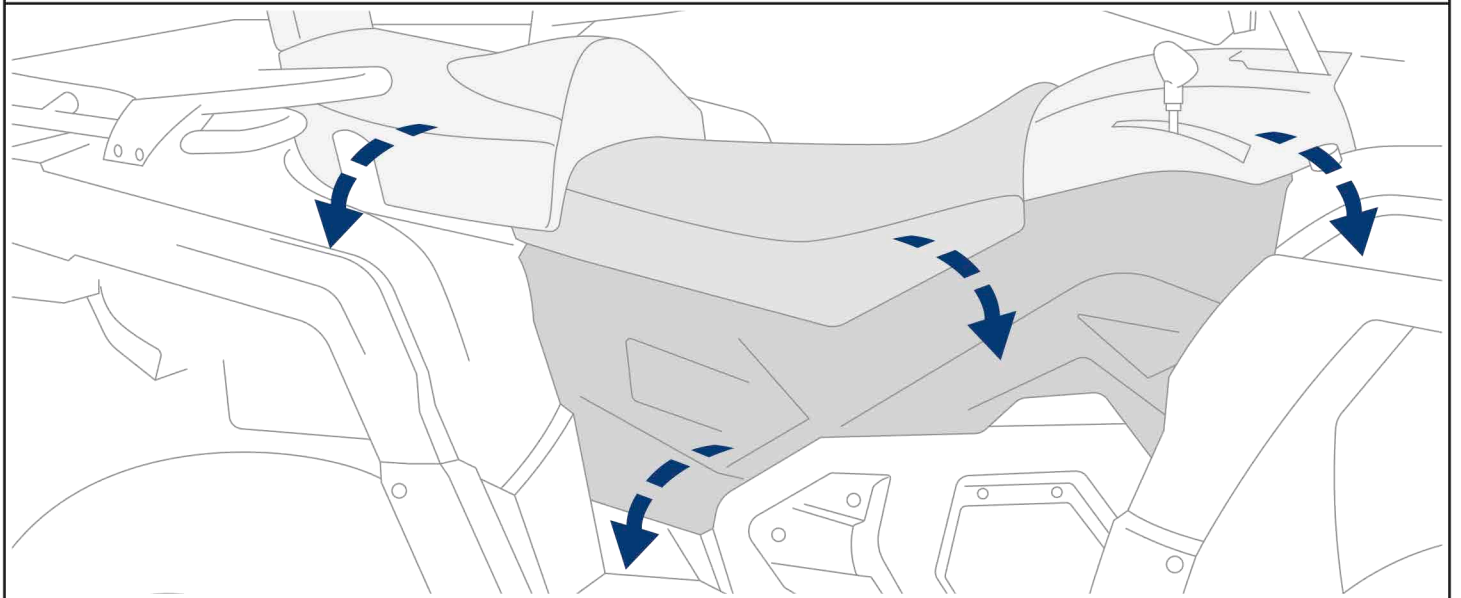
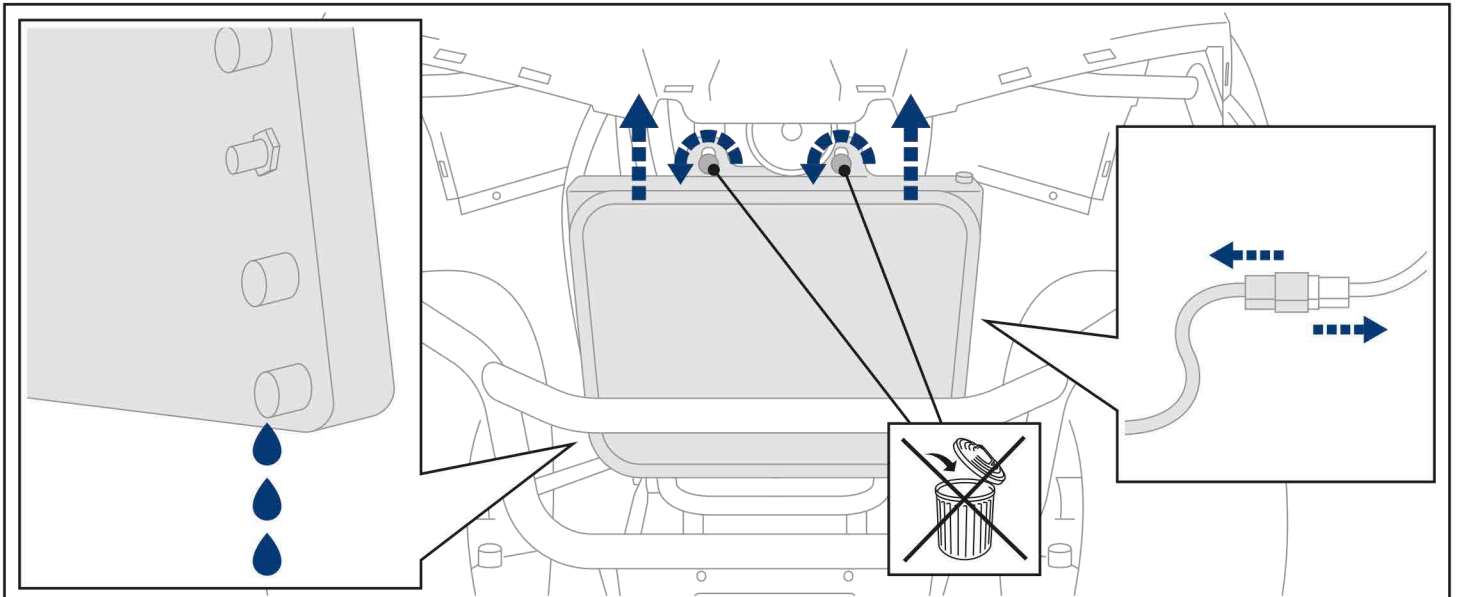

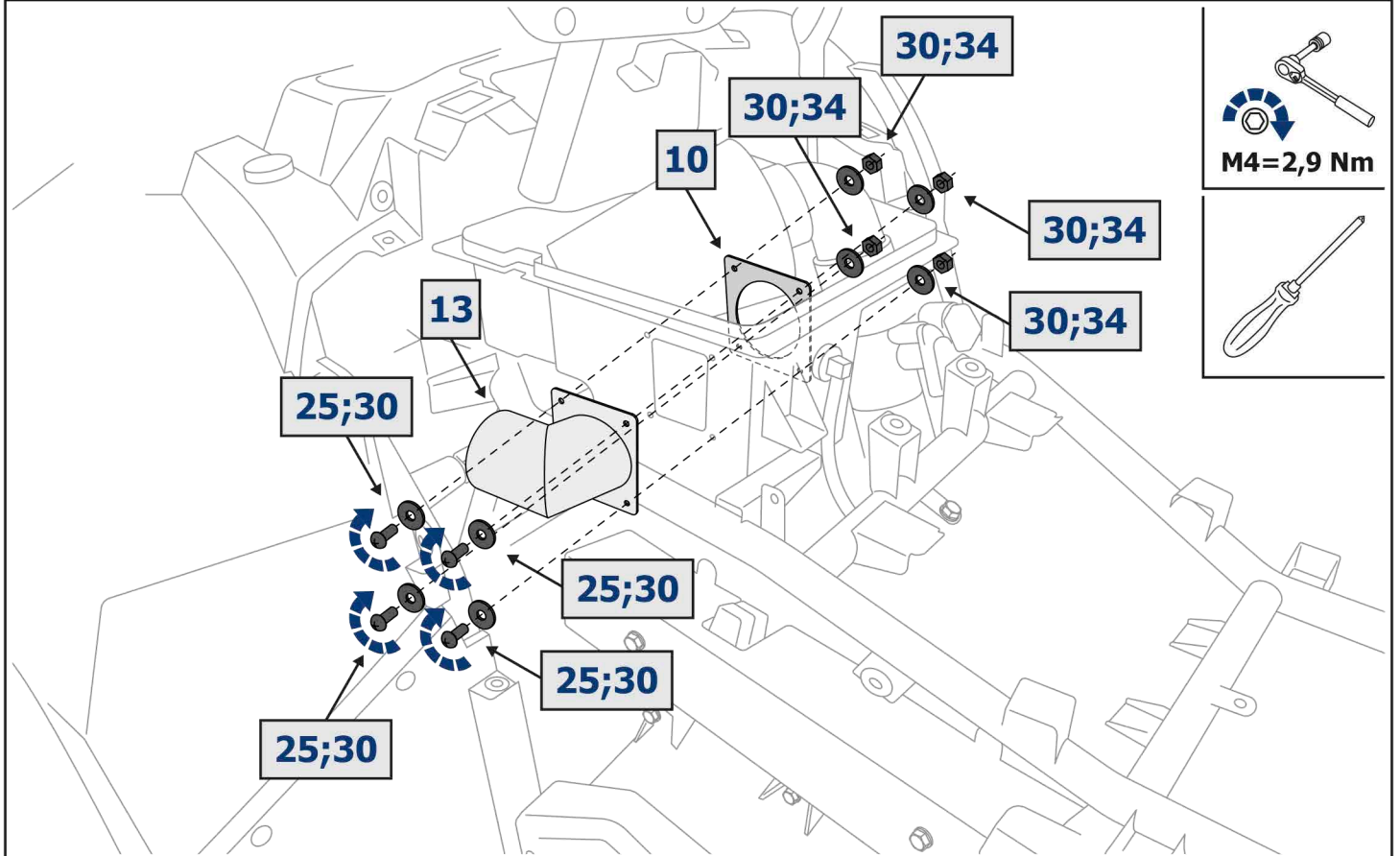
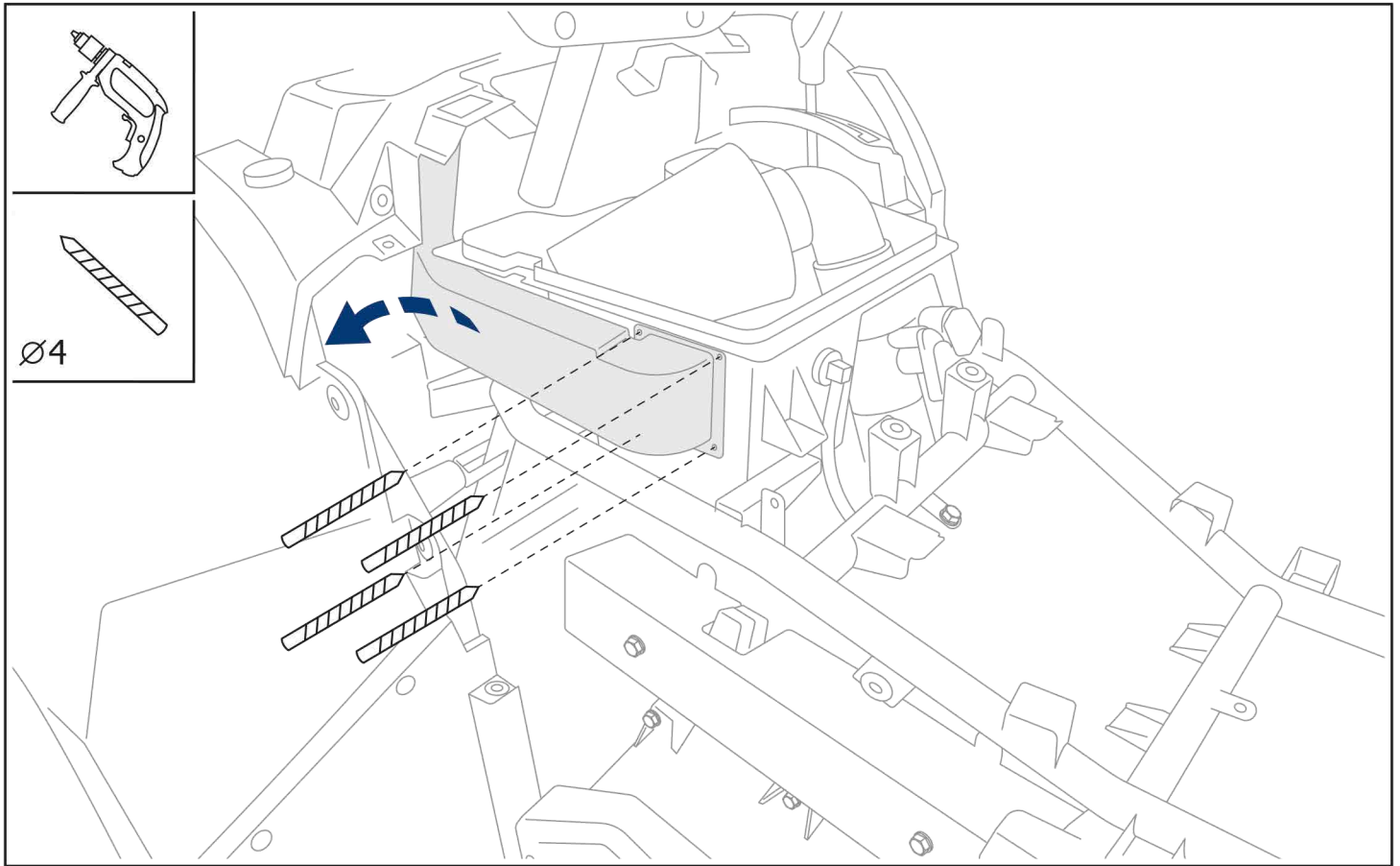

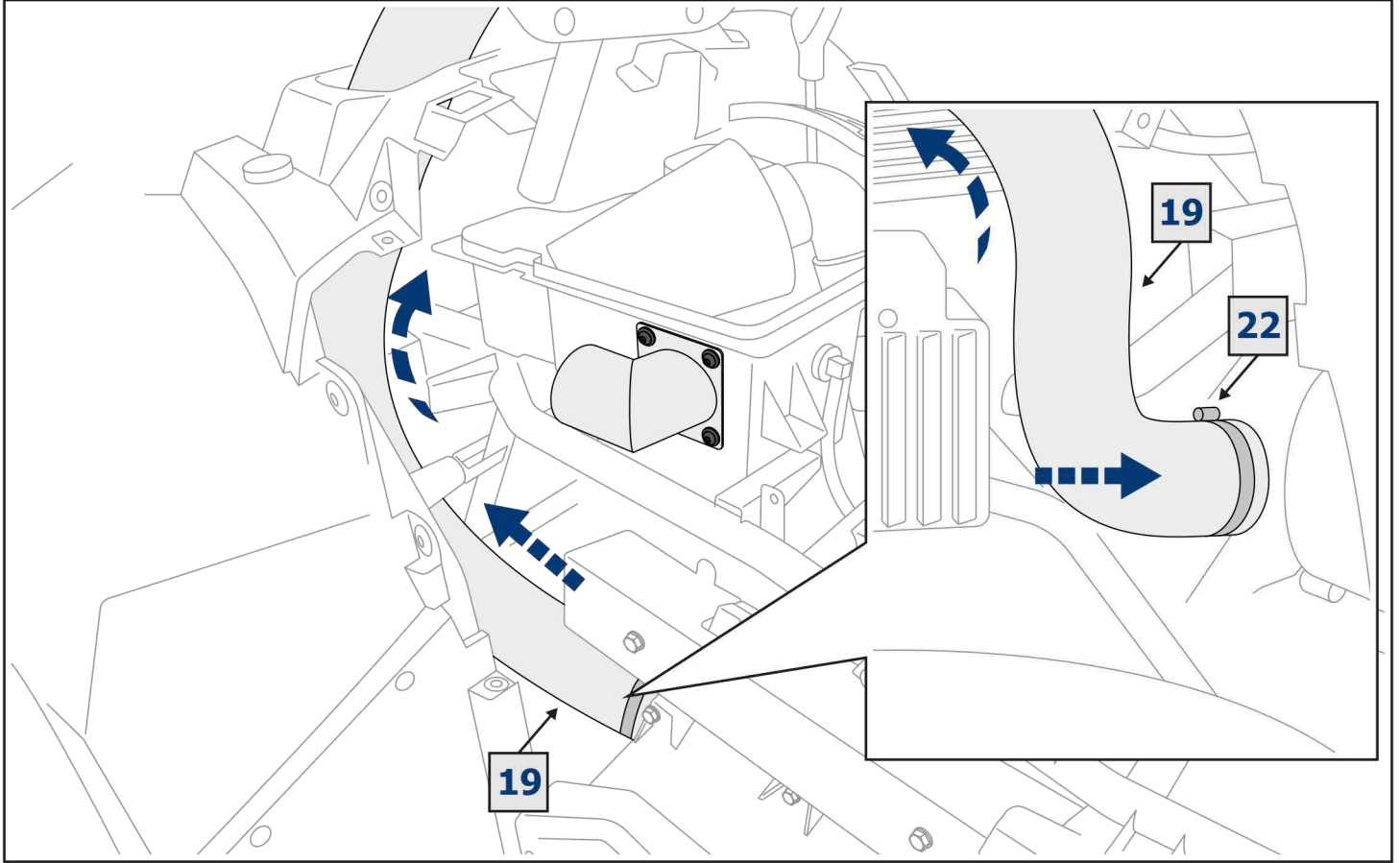
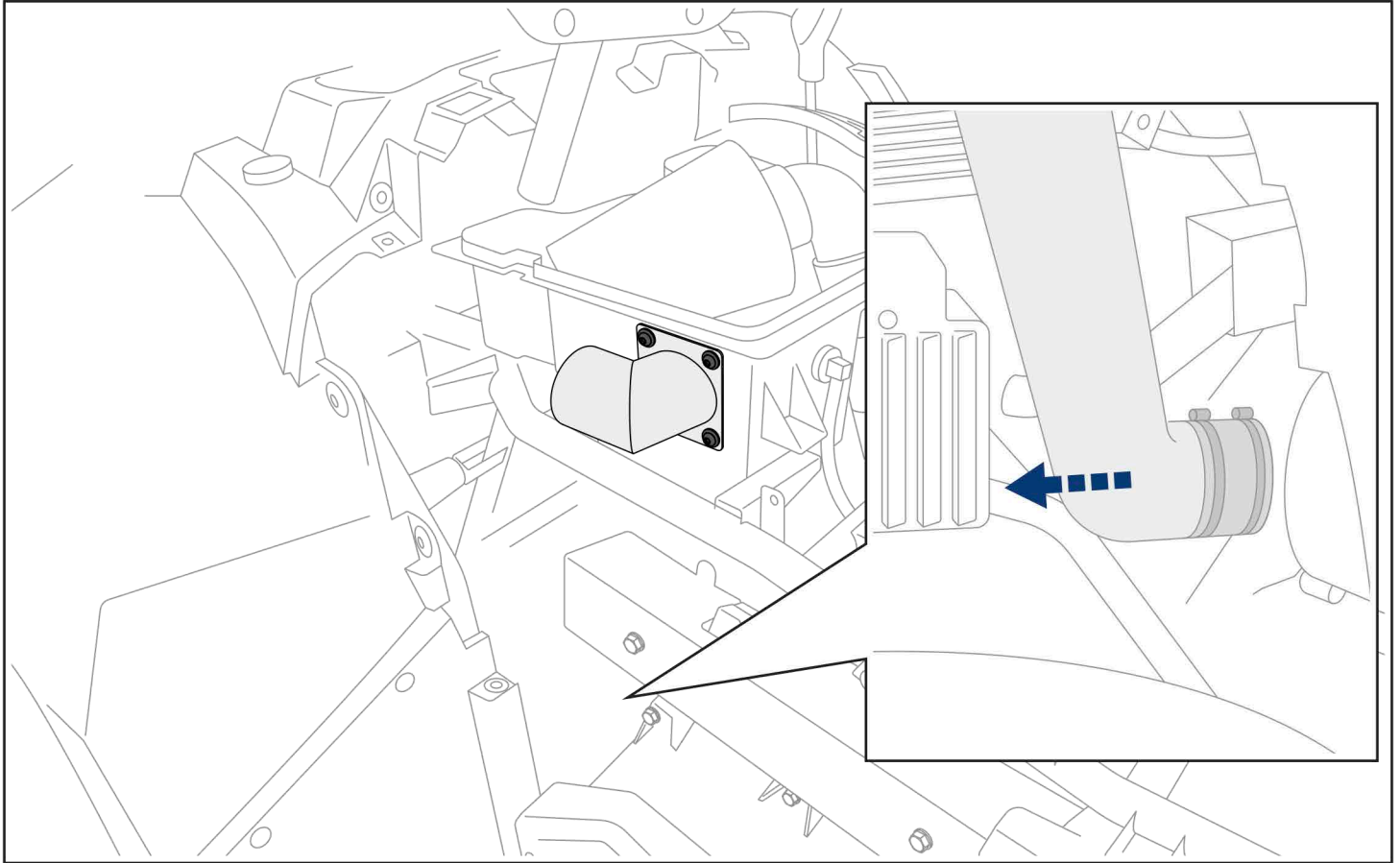

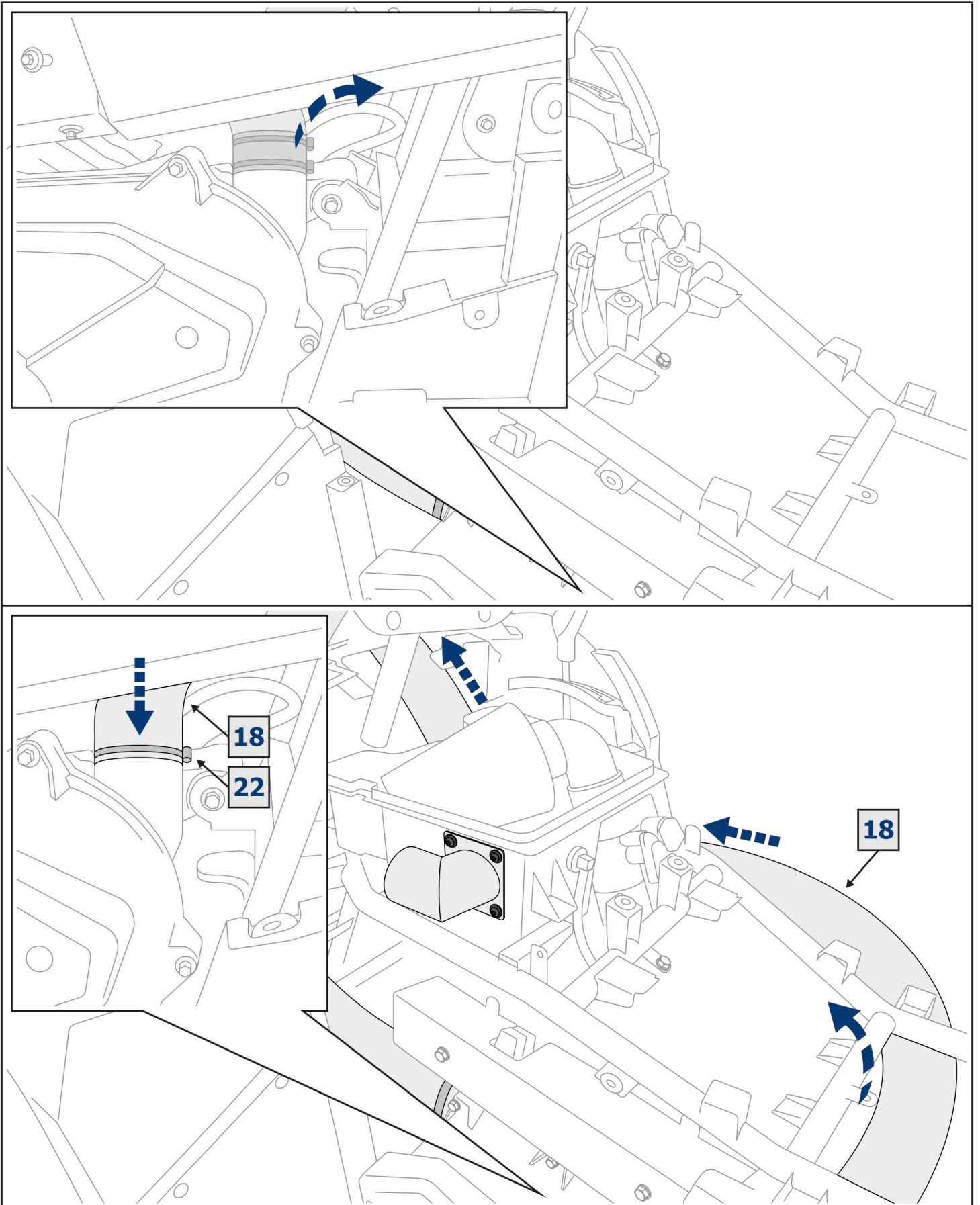

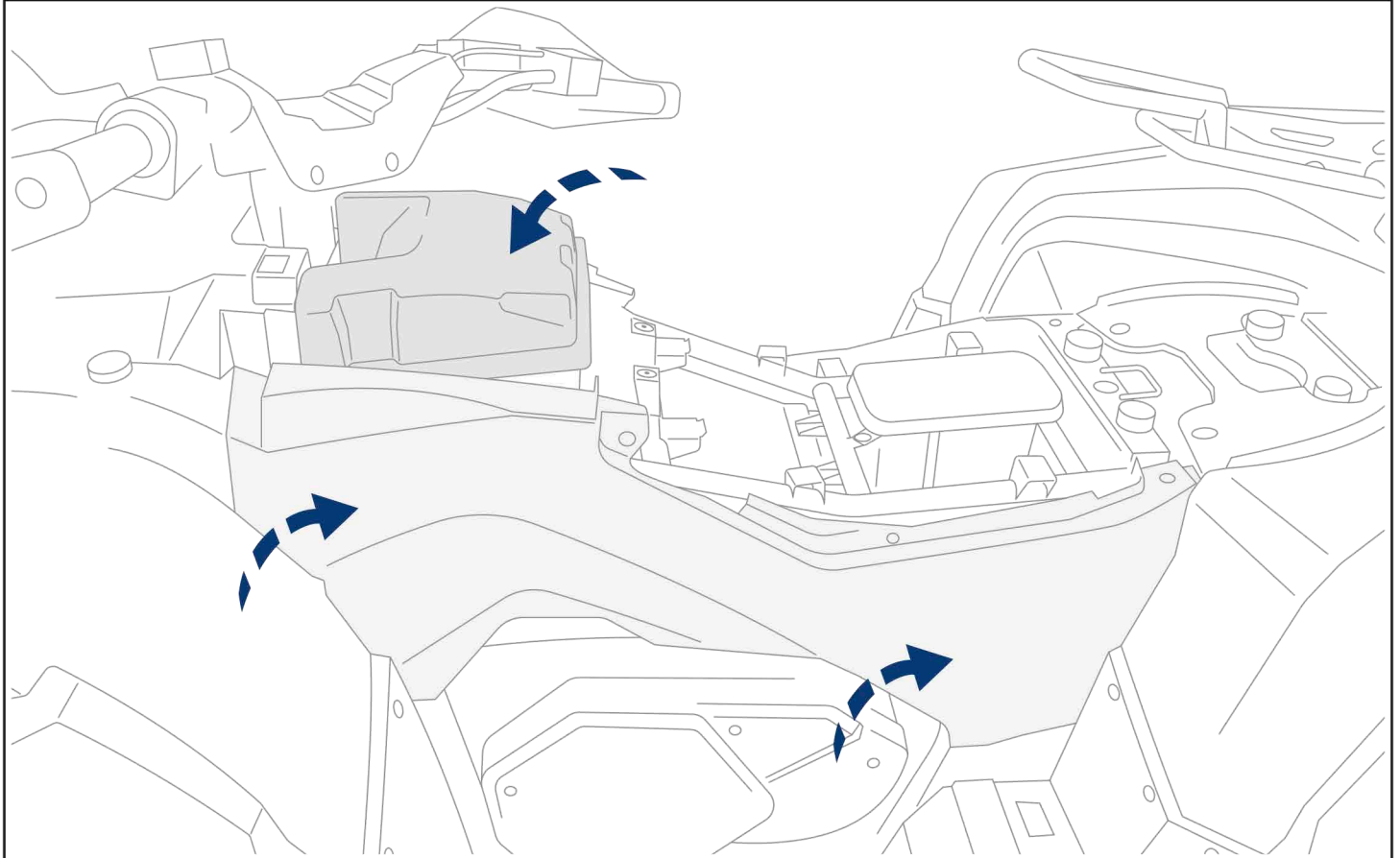
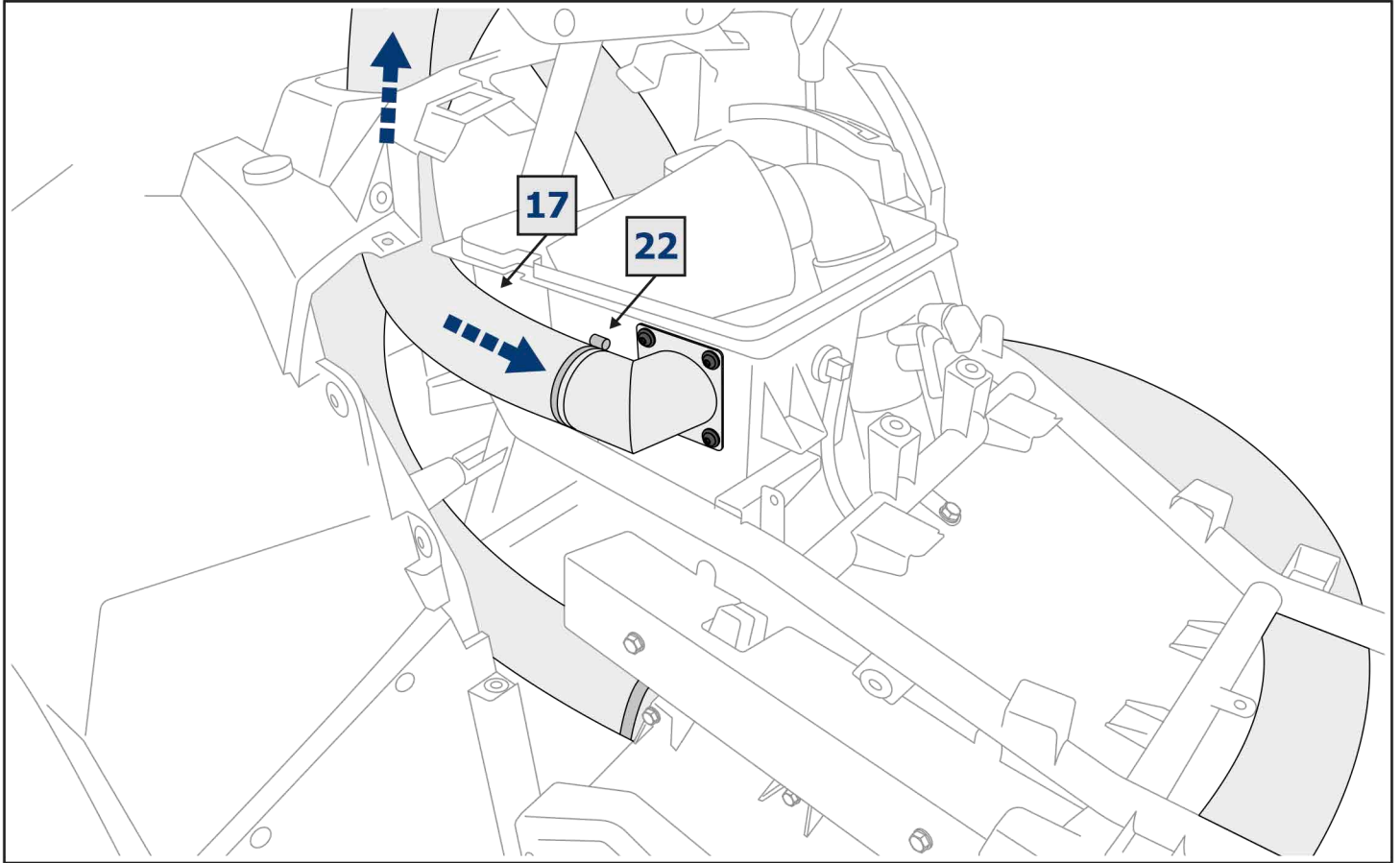

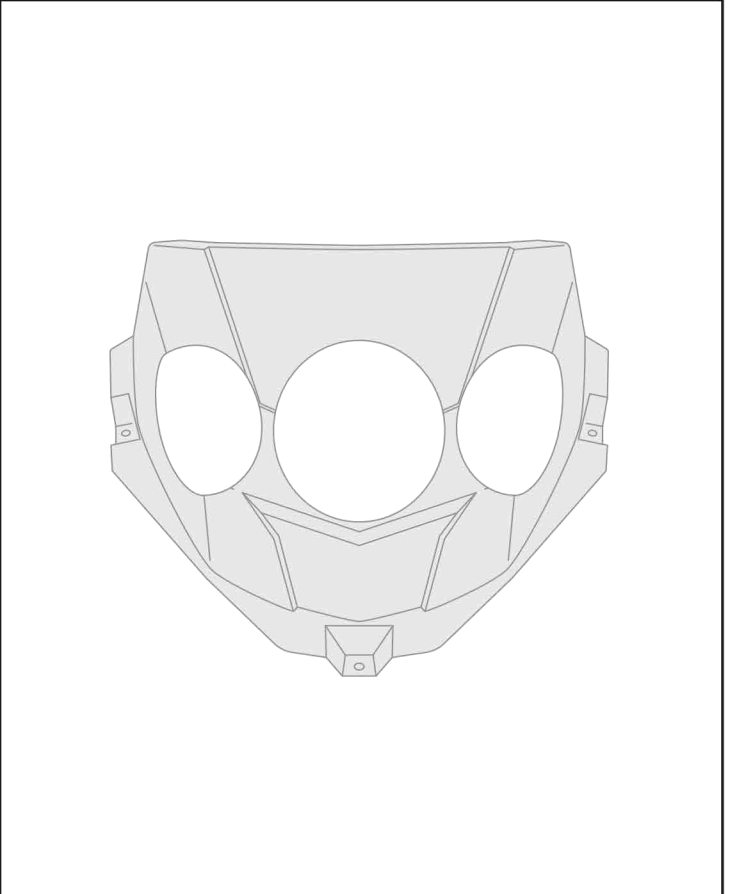
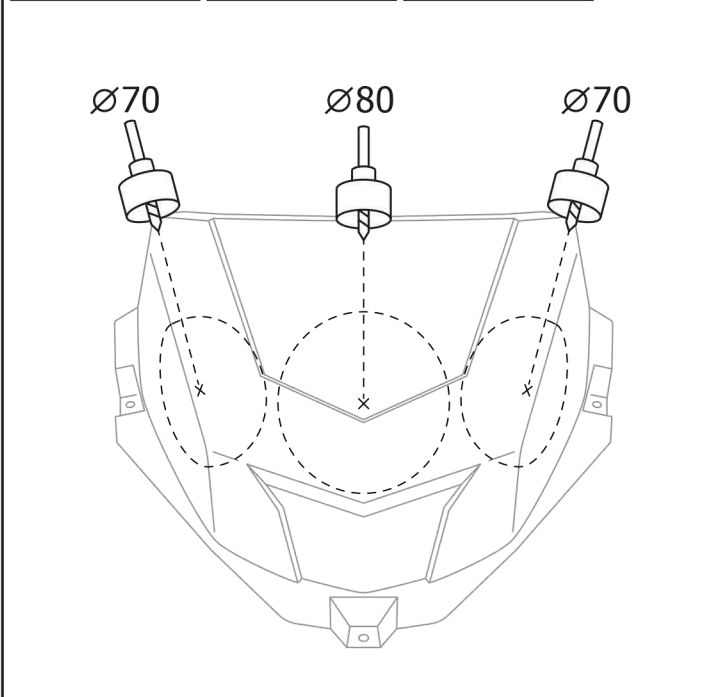
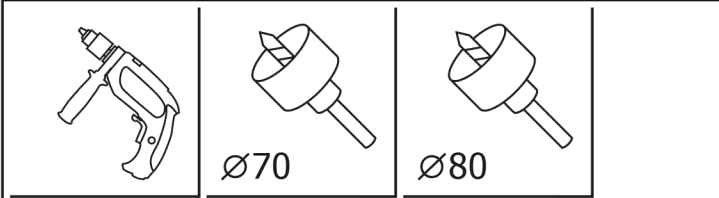
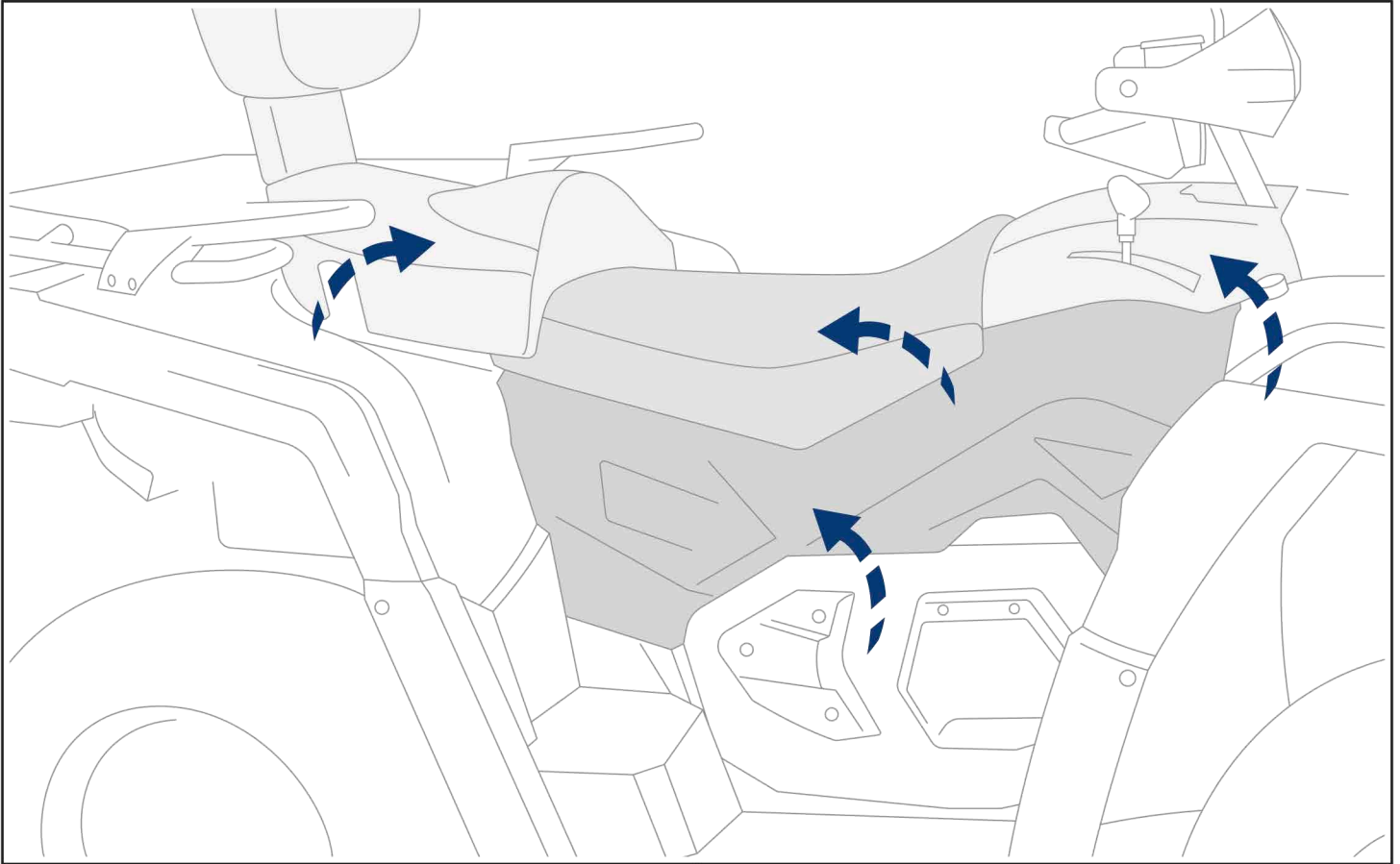

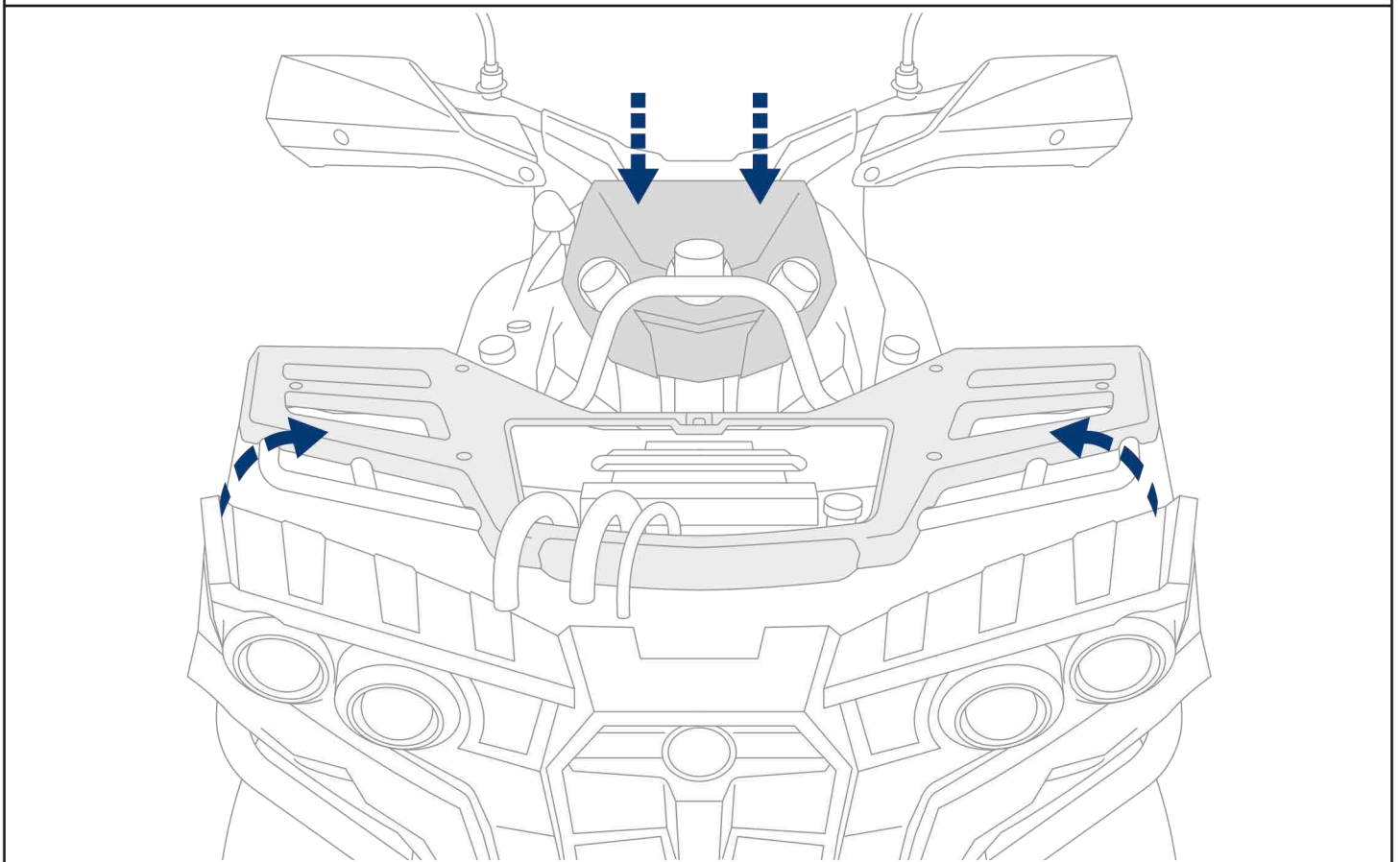
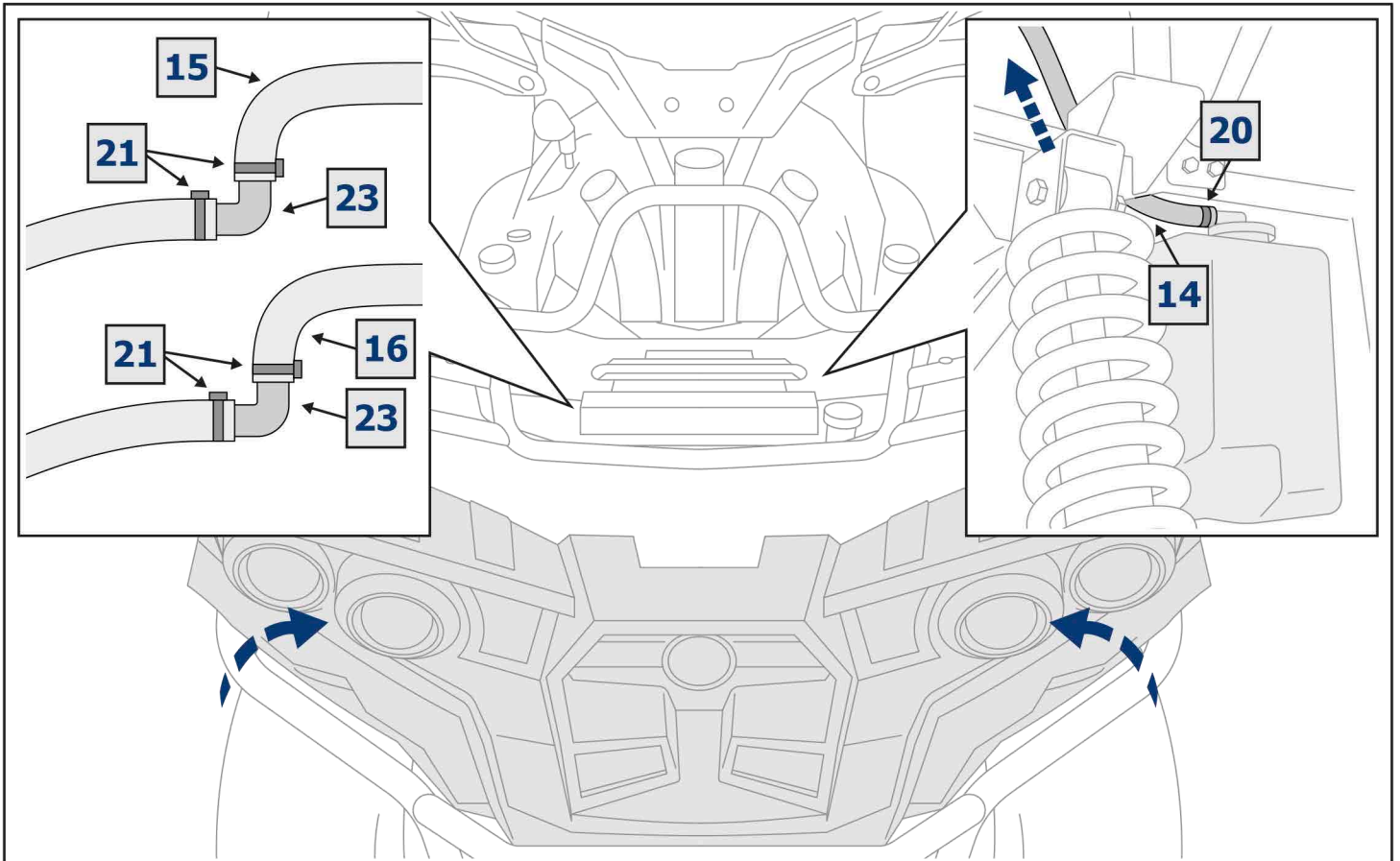

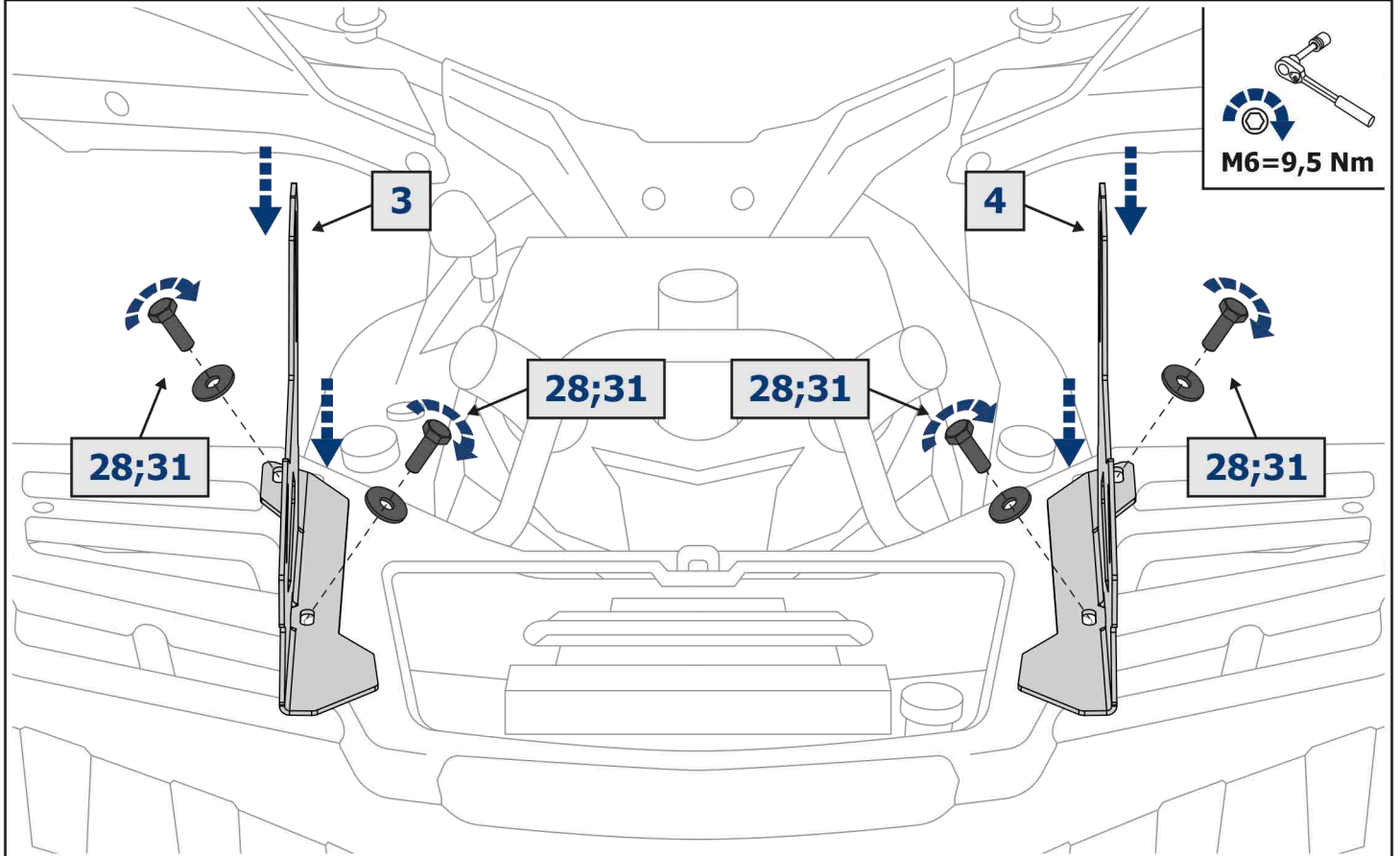
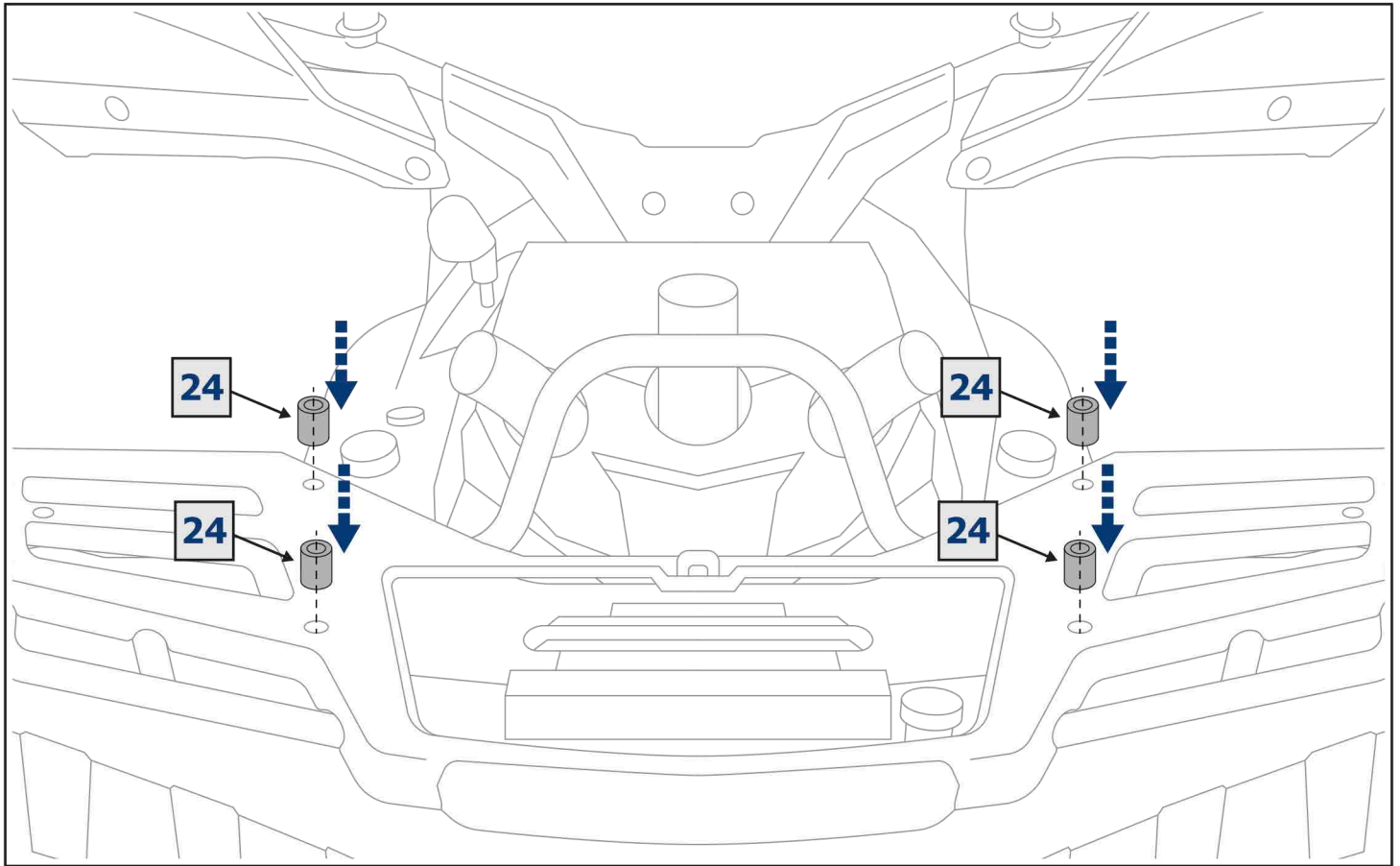

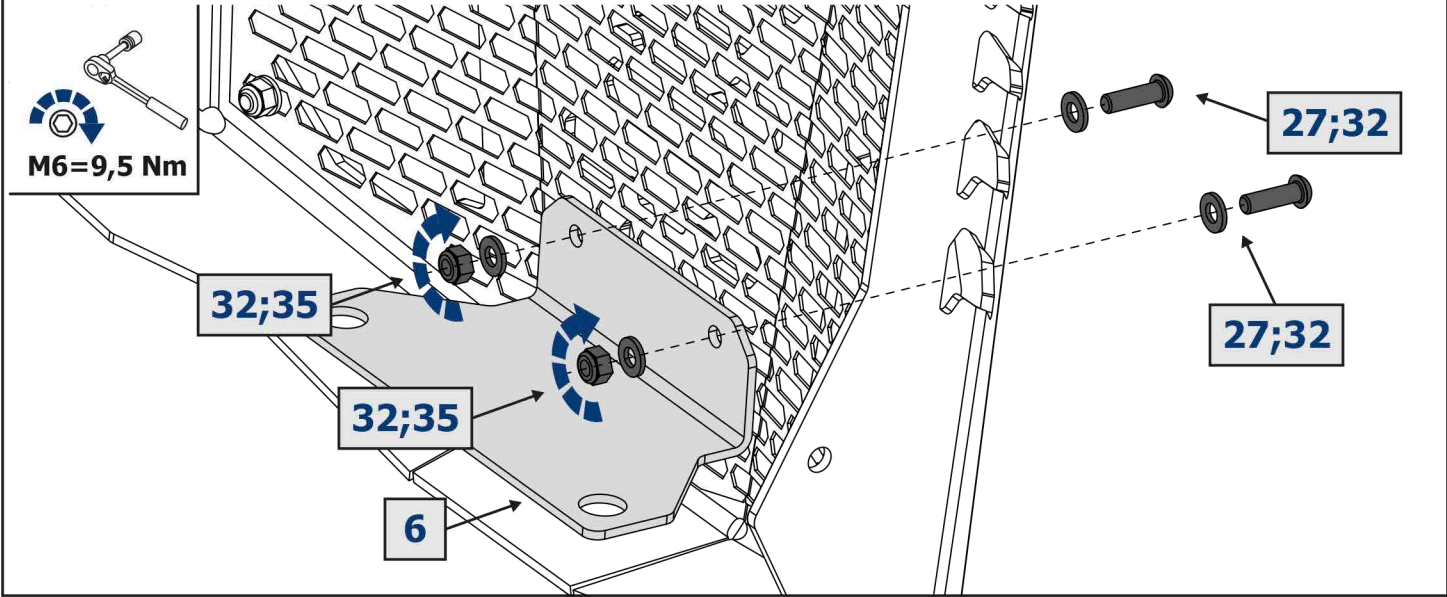
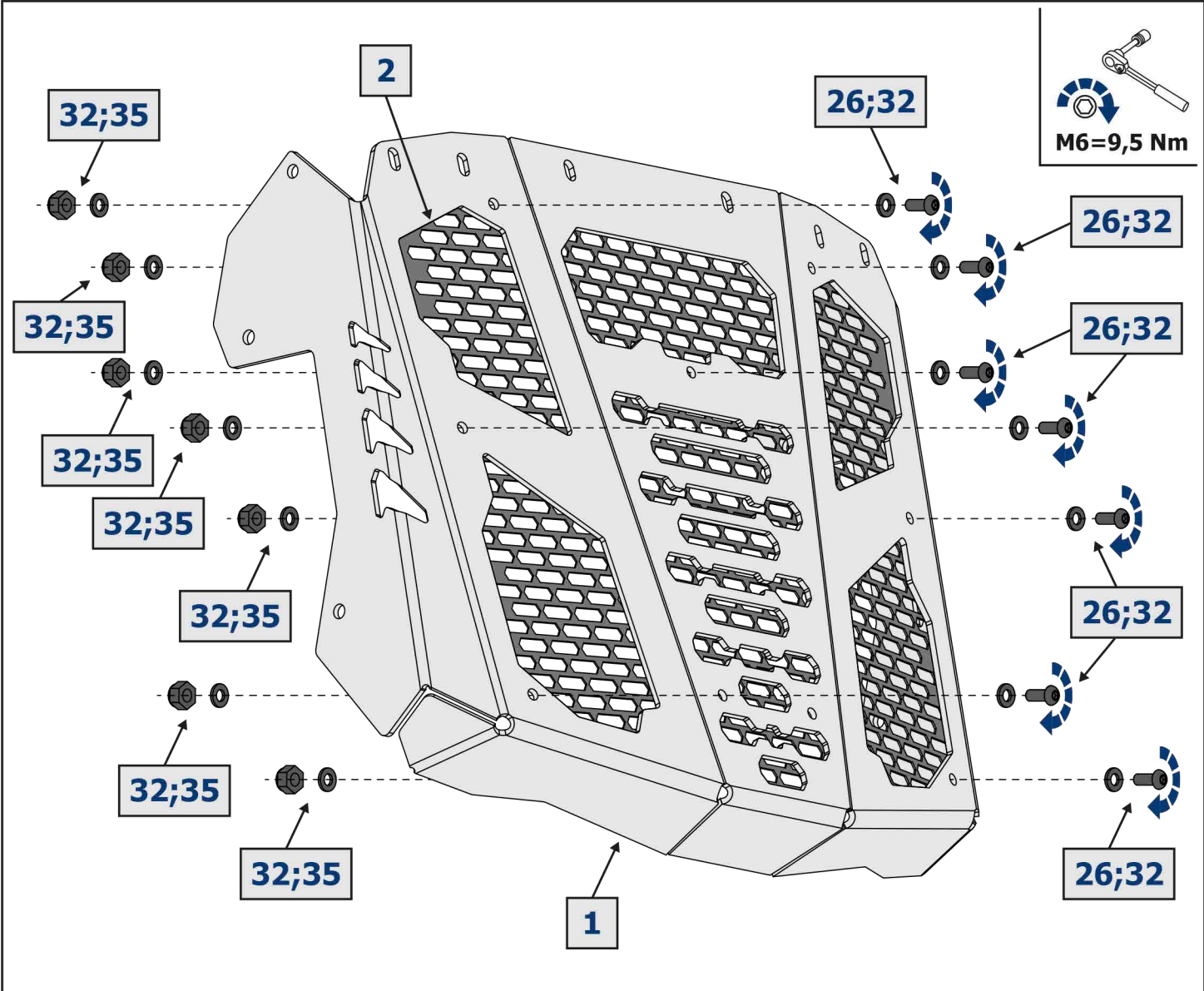

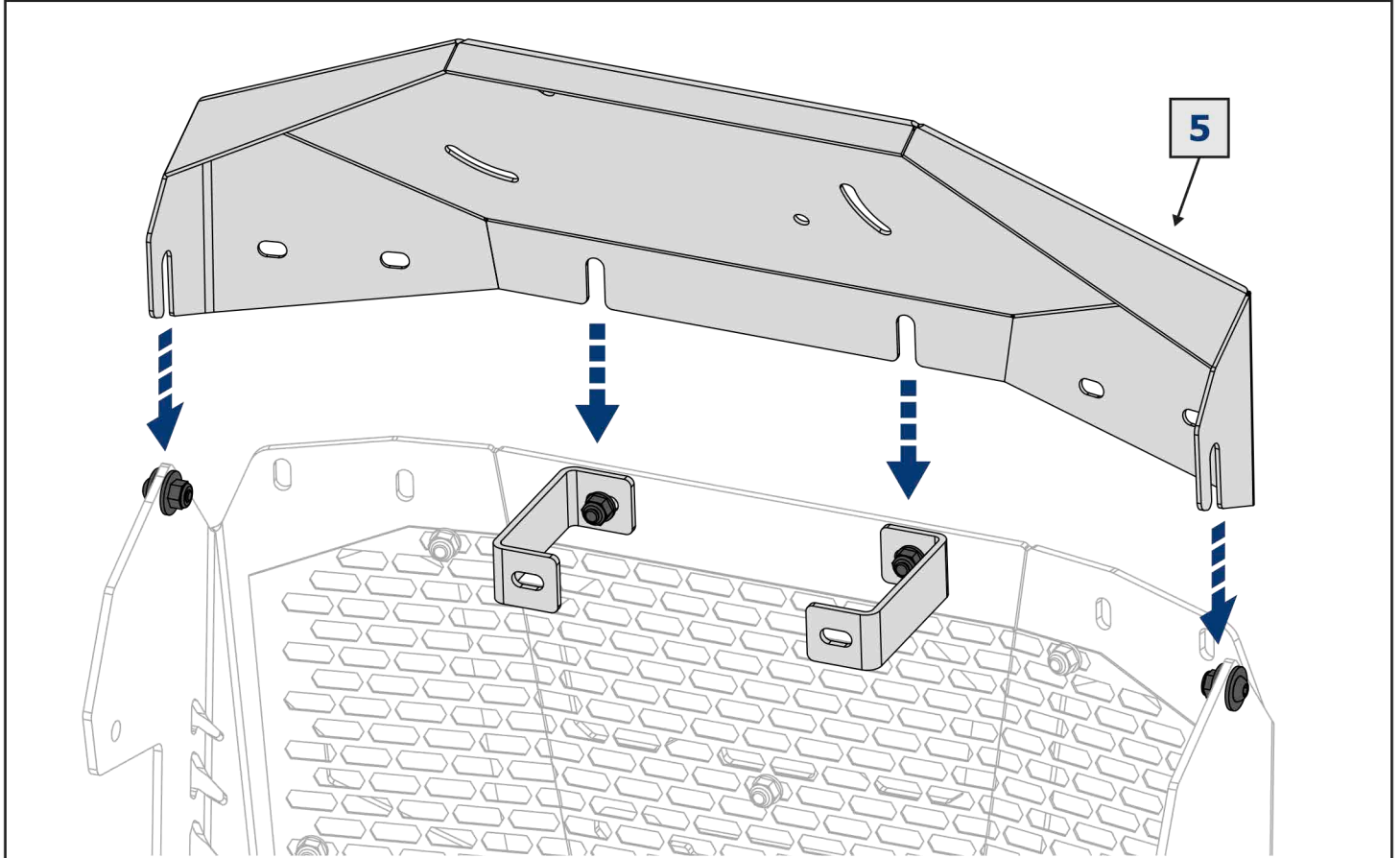
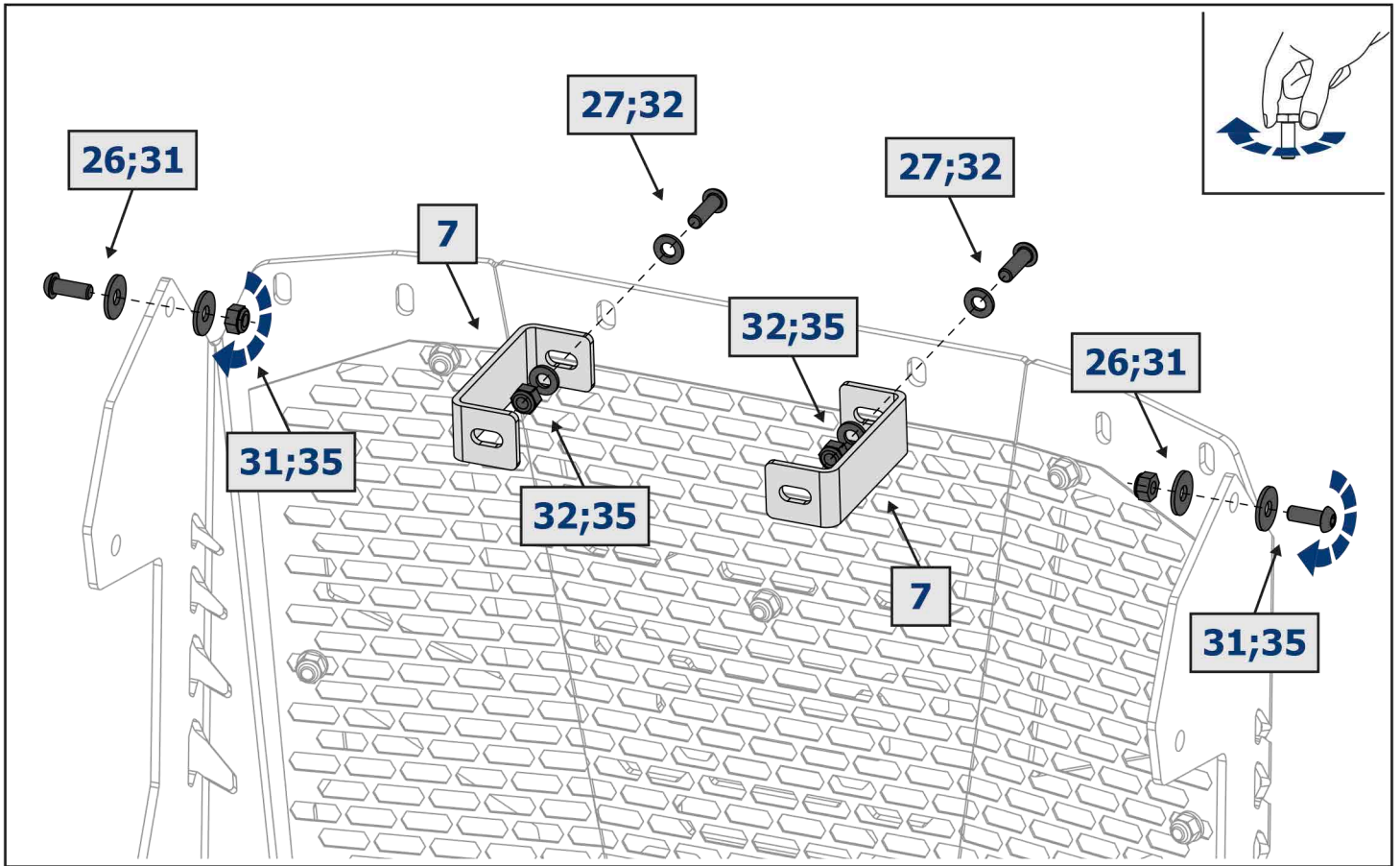

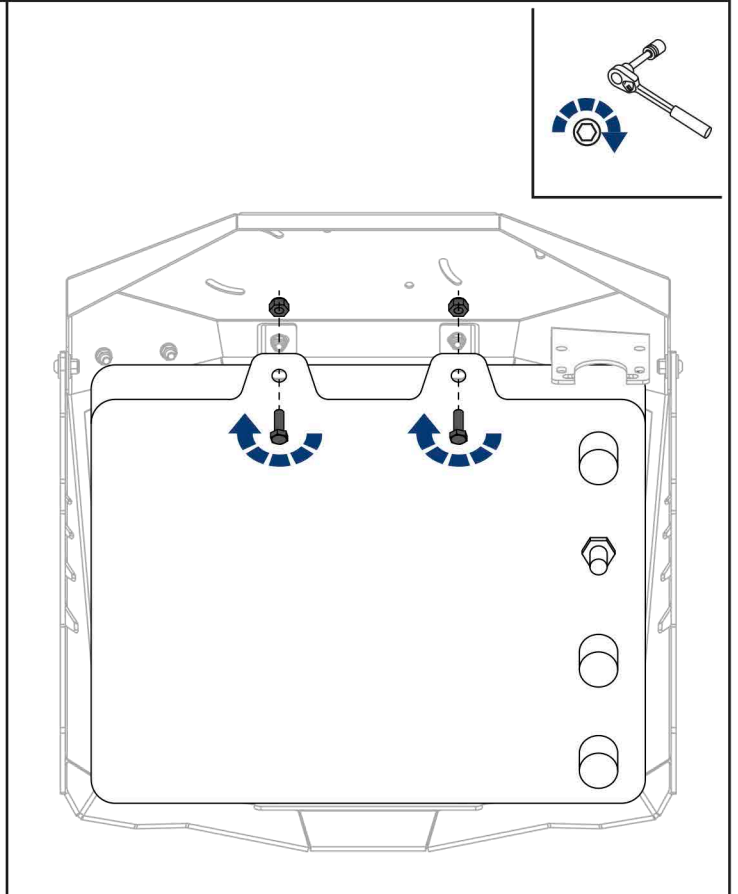
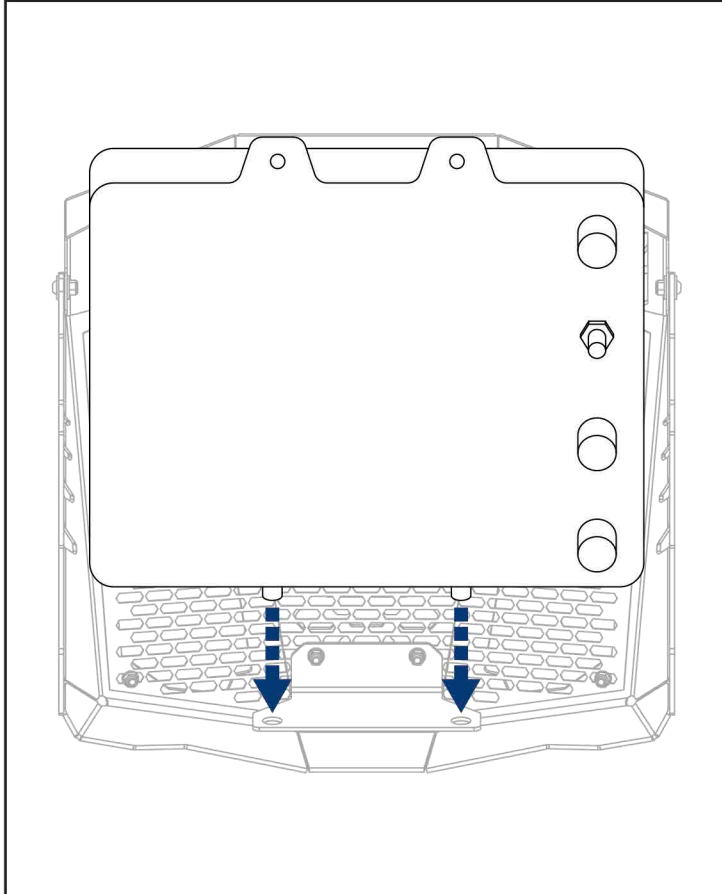
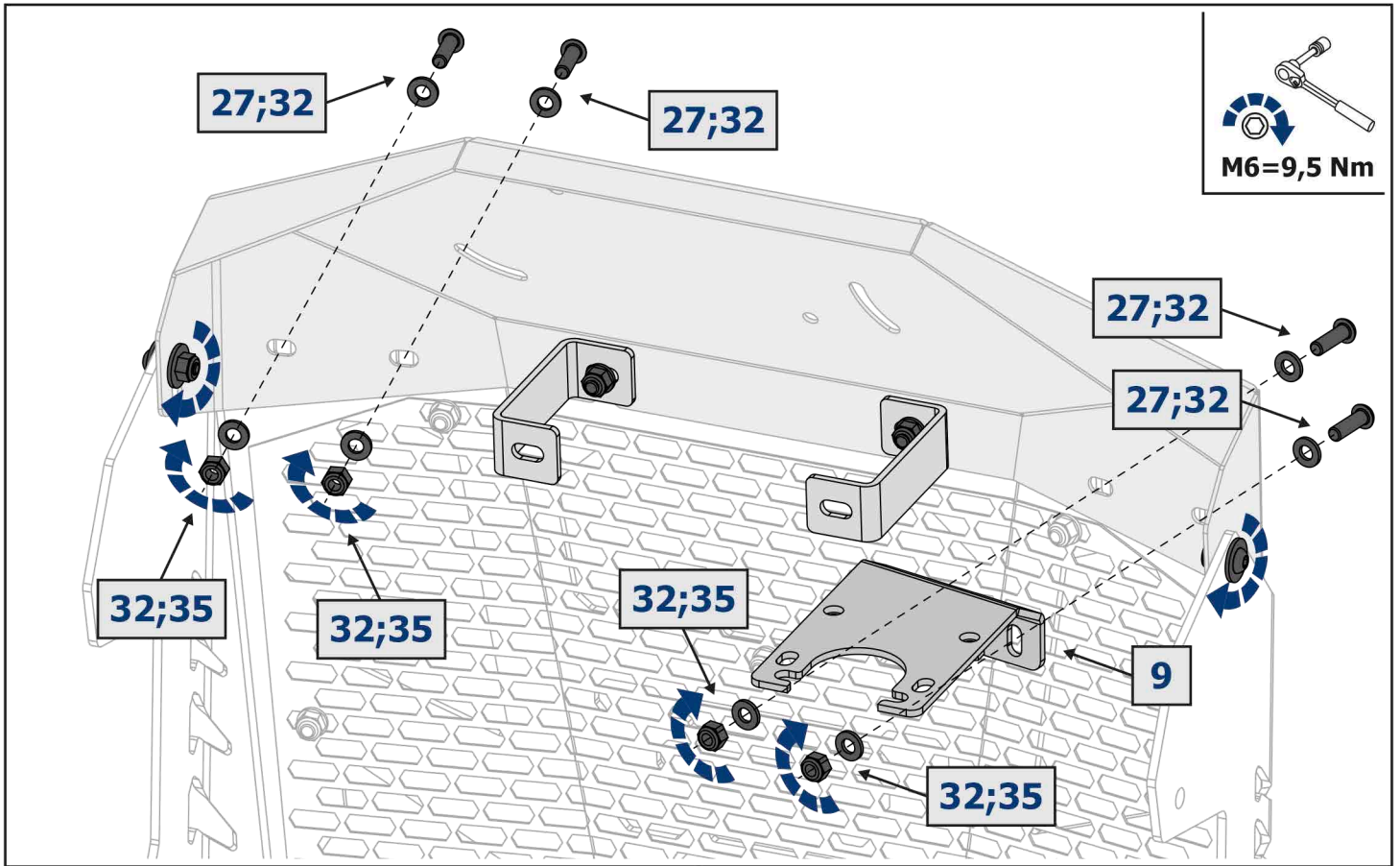

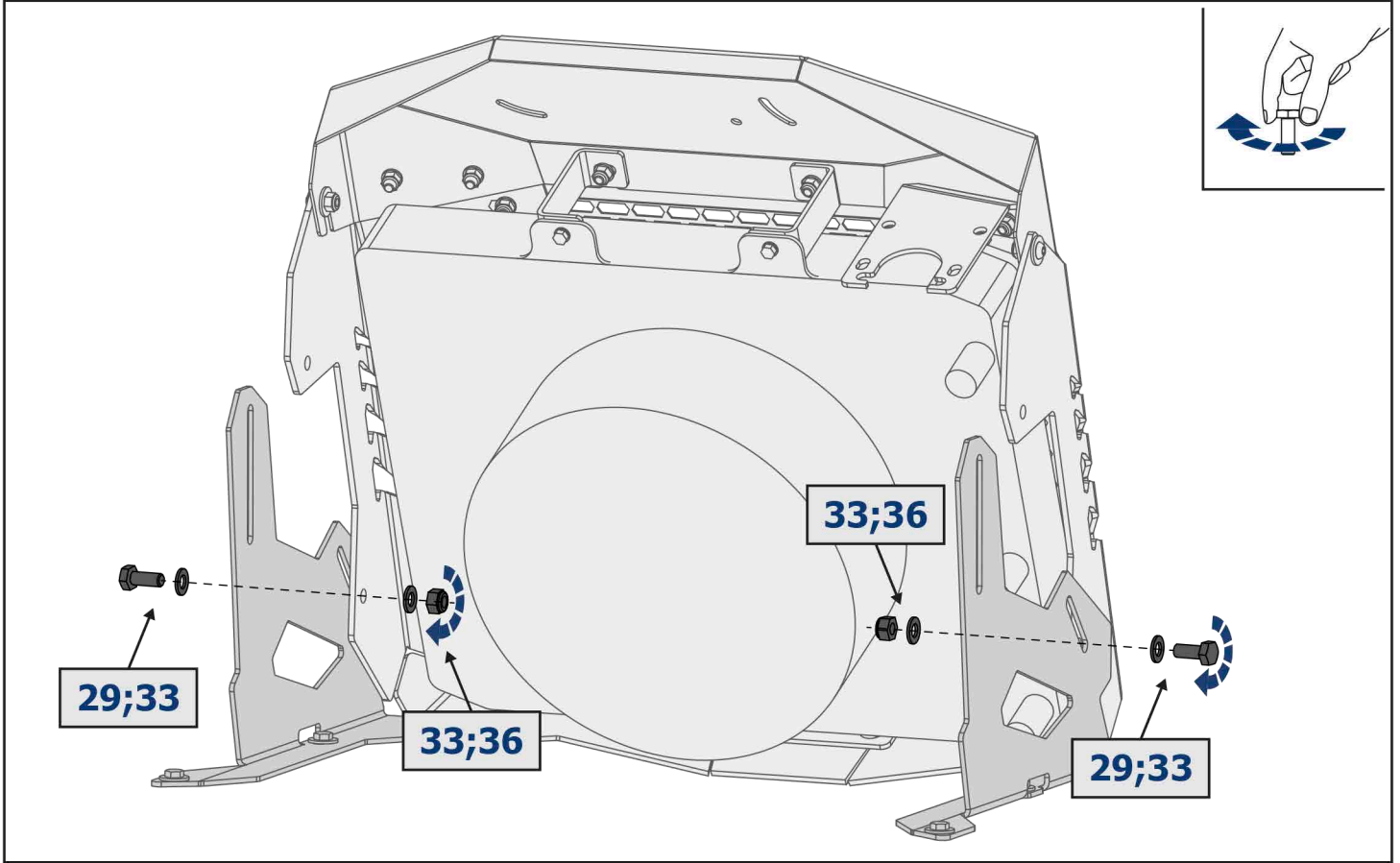
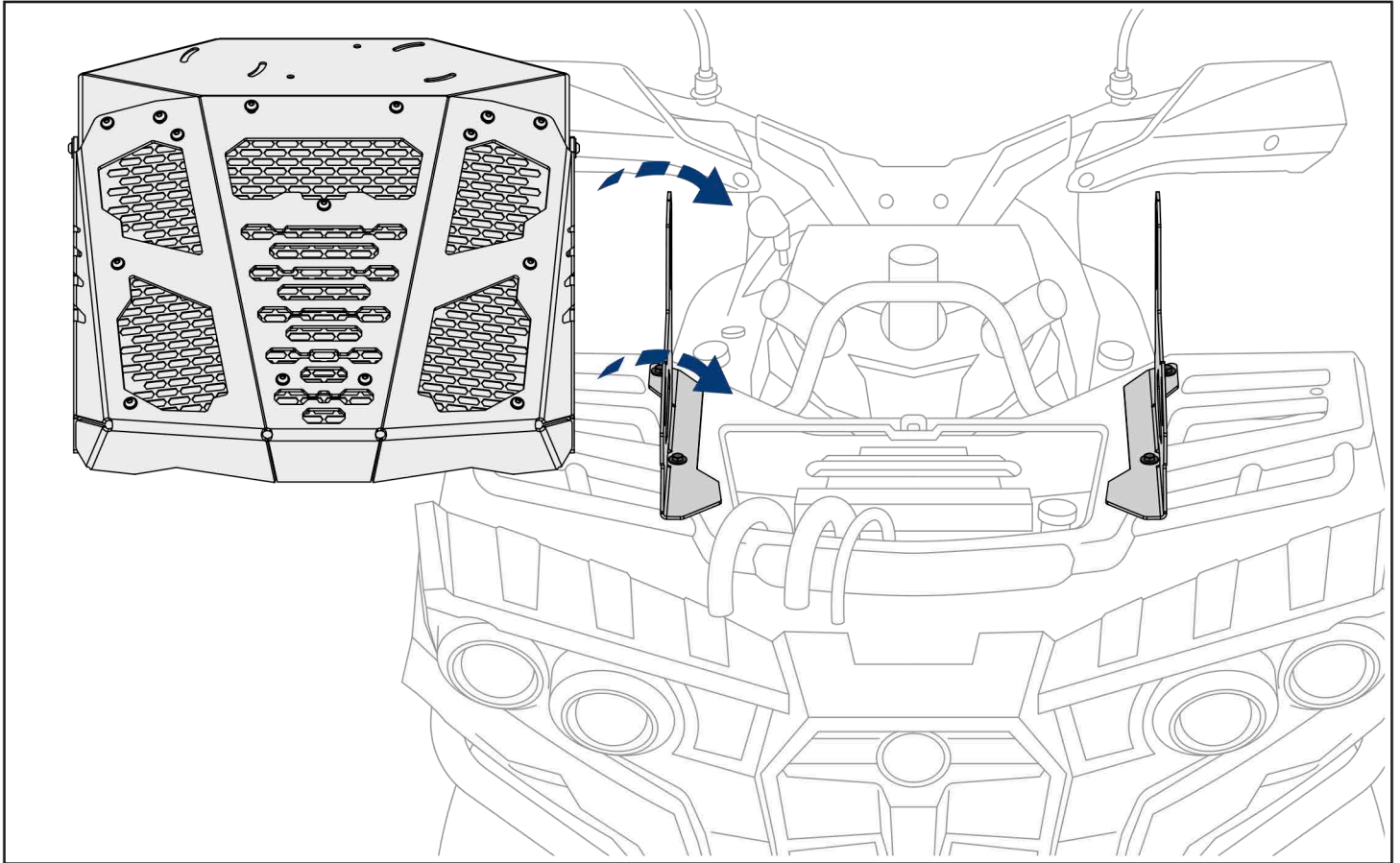

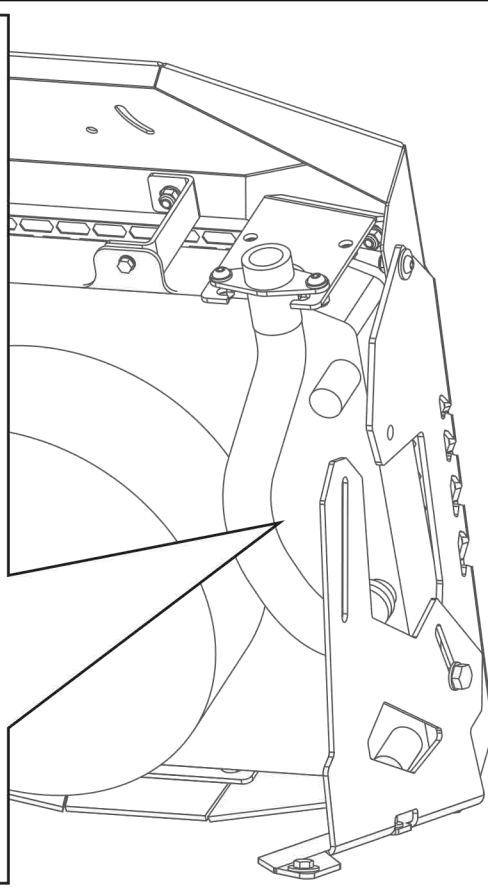
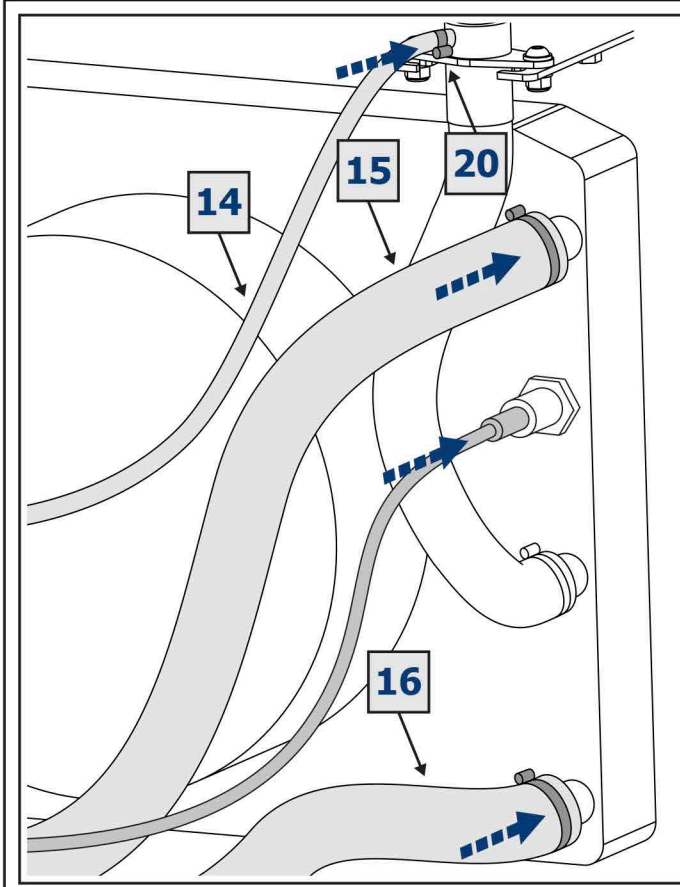
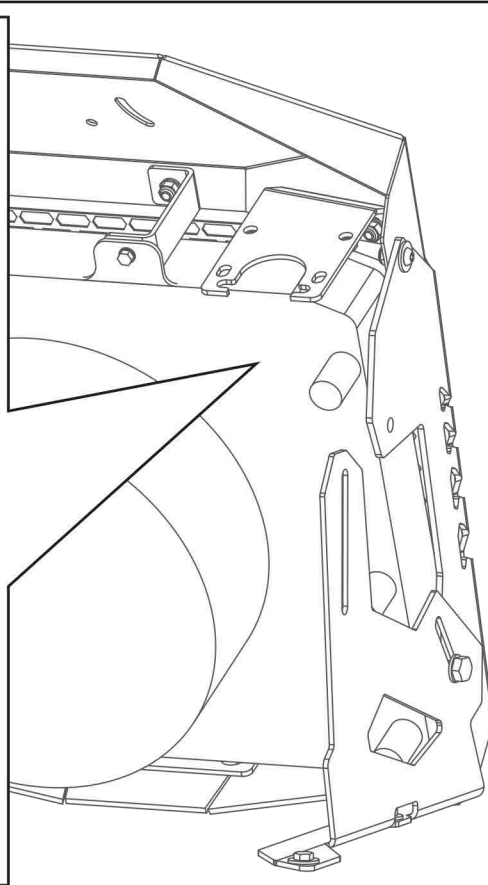
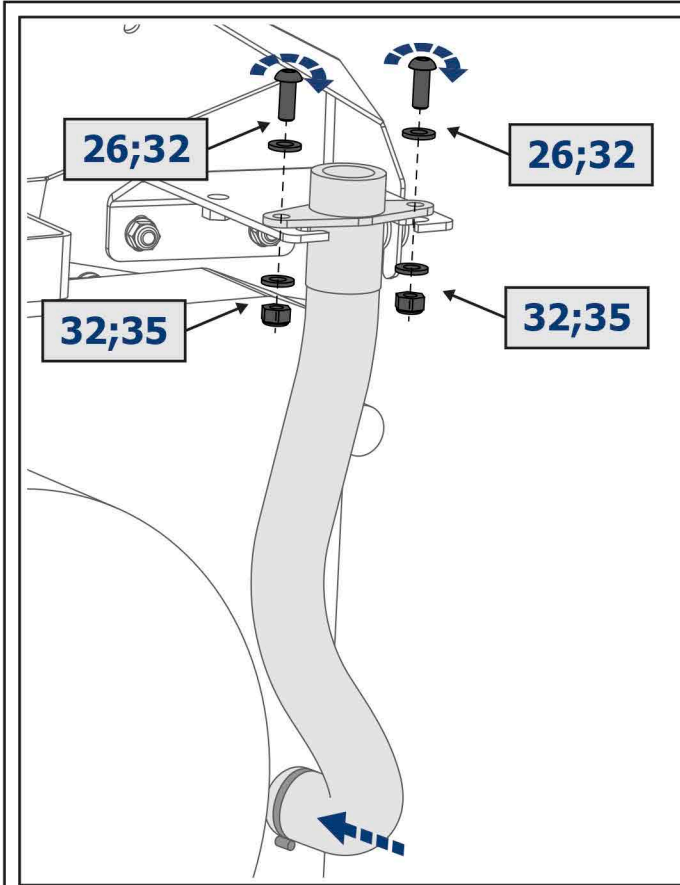

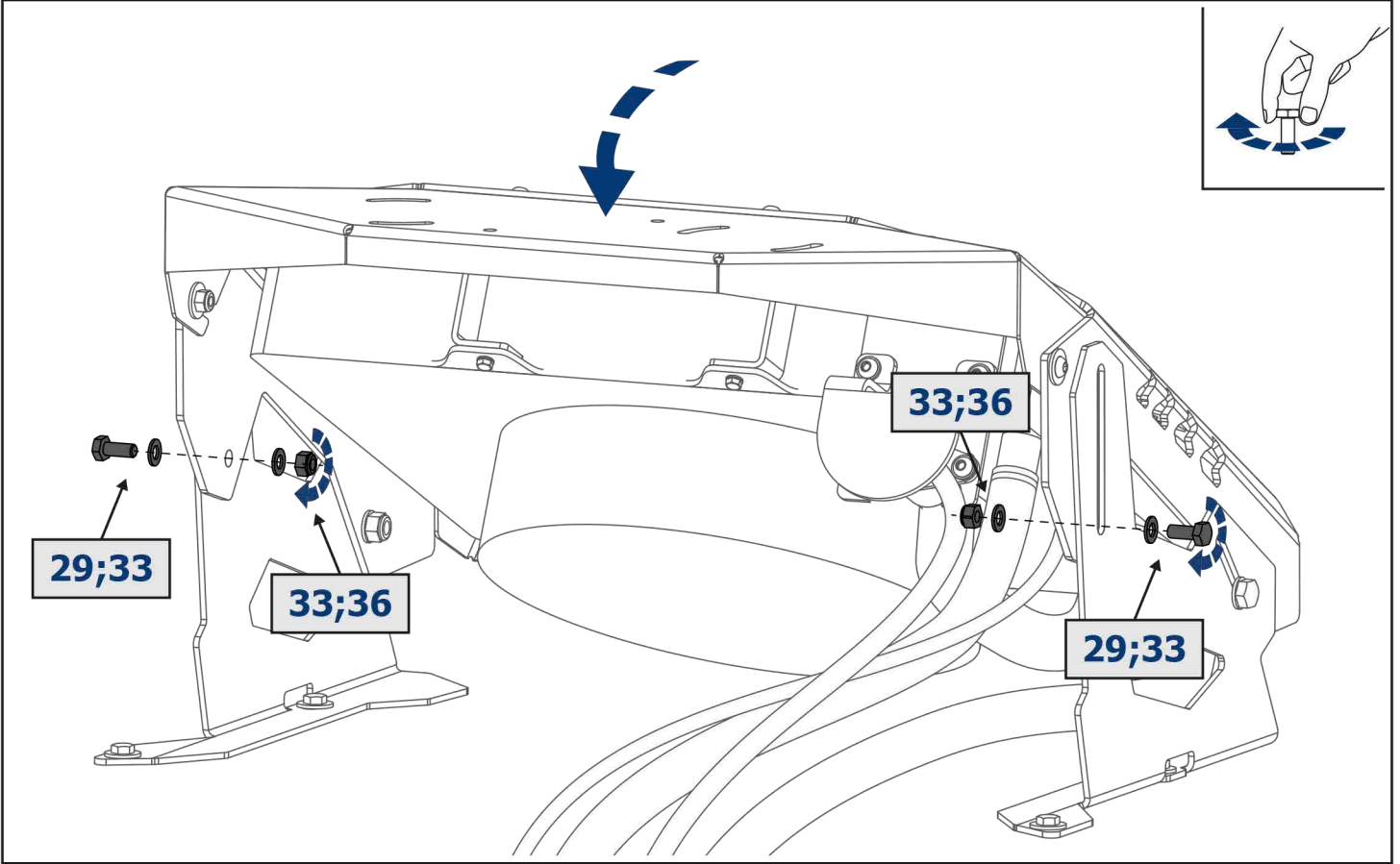
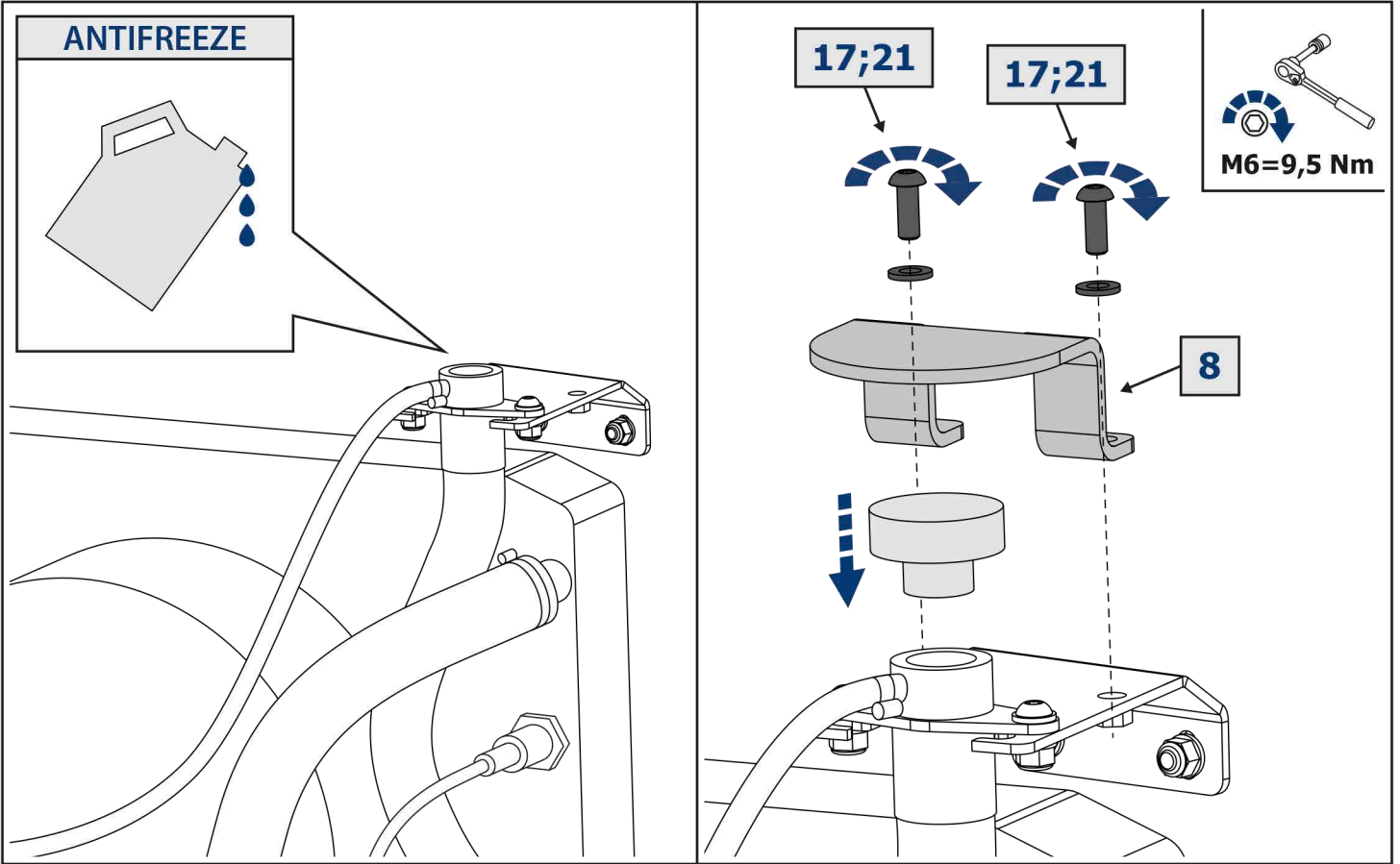

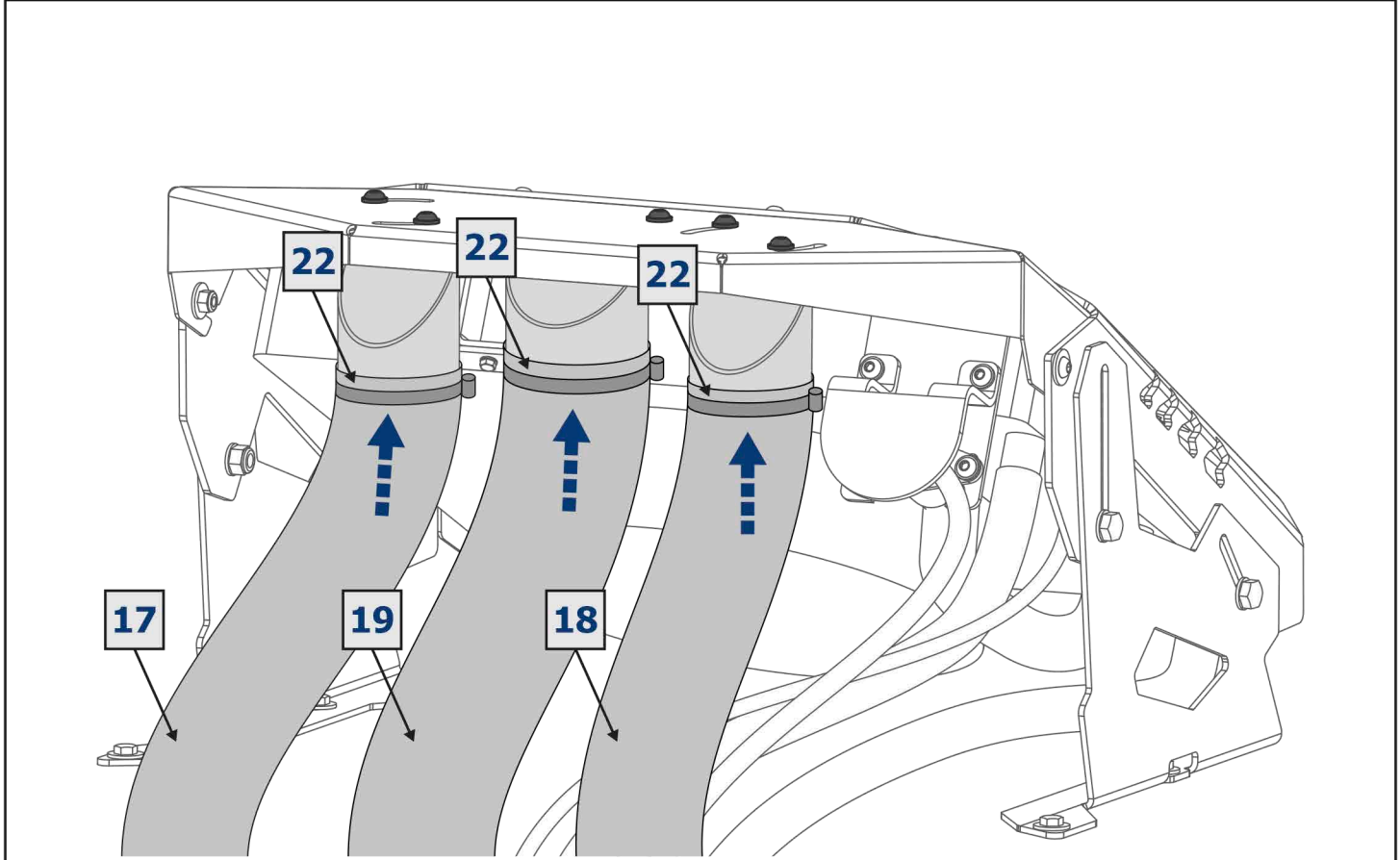
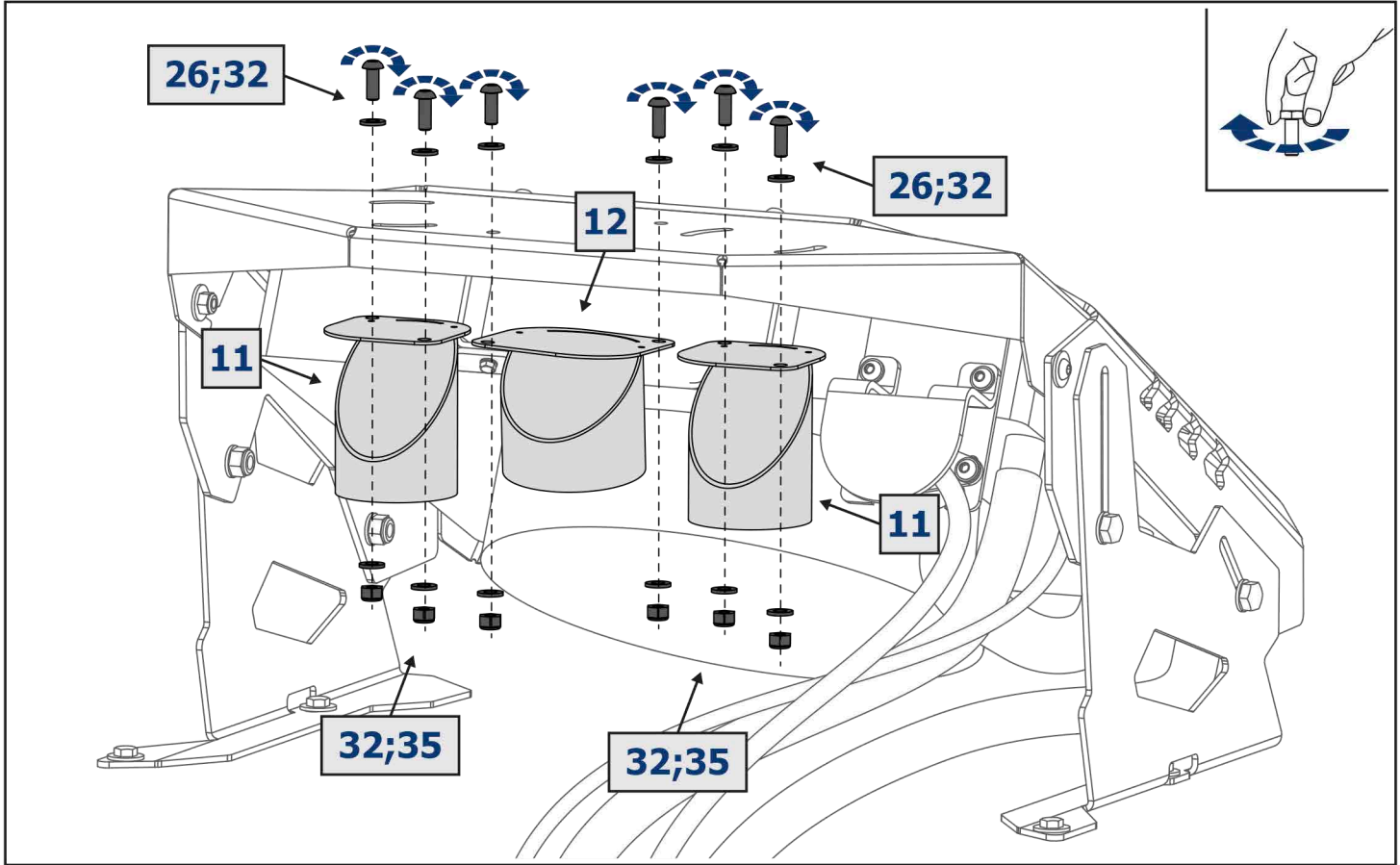

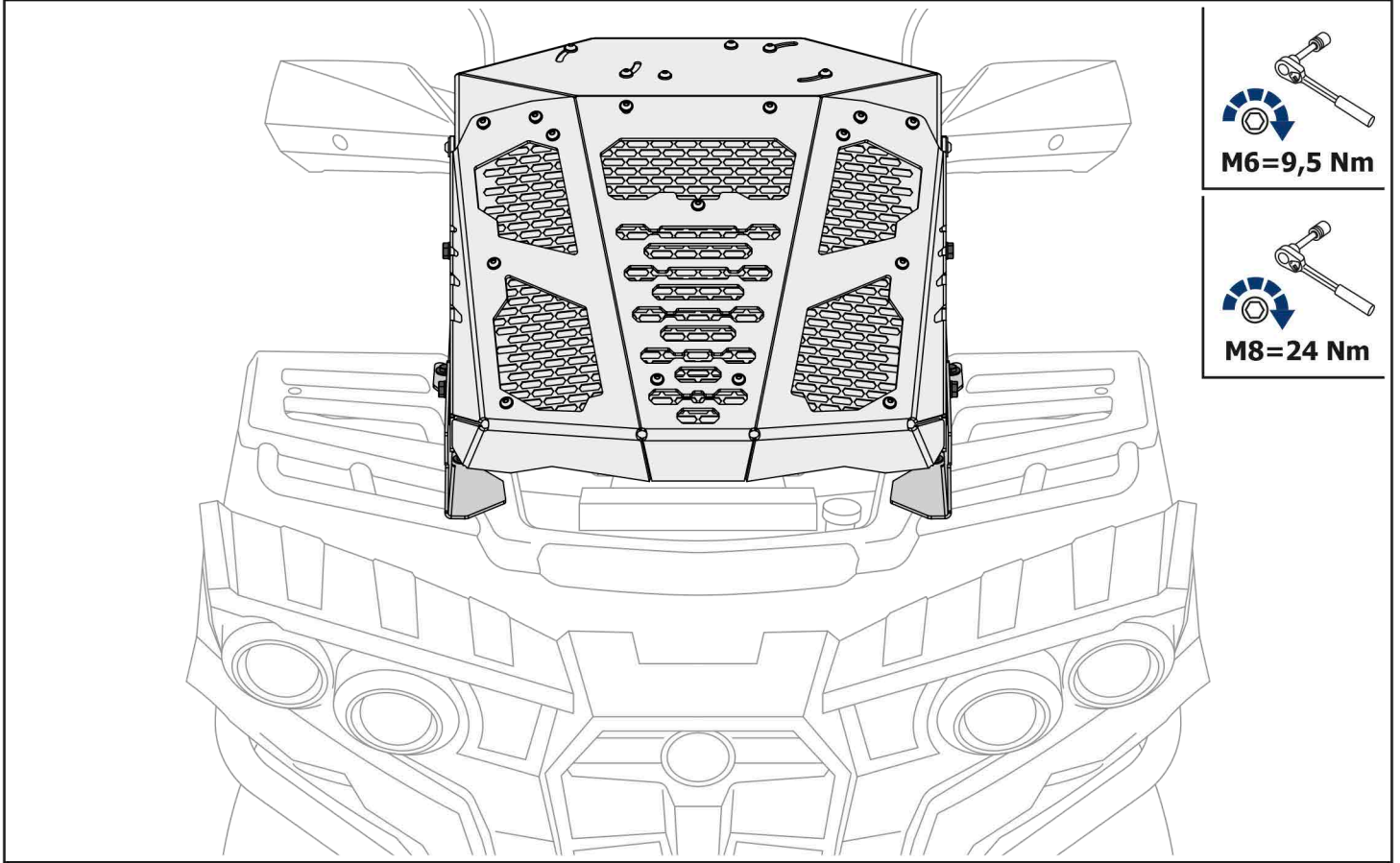
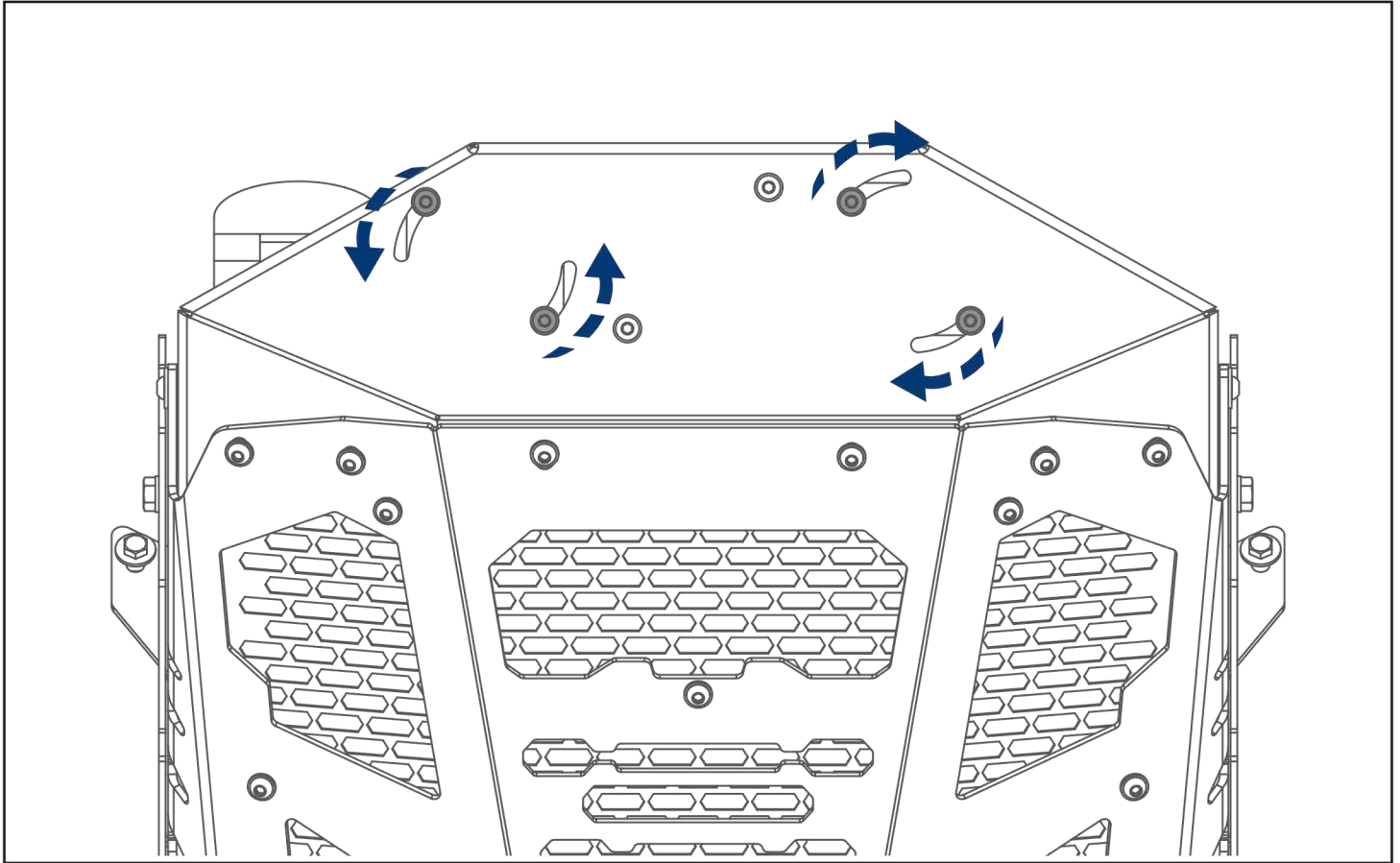

EN Attach temperature sensor connectors, fan connector and fan breather connector.

DE Schließen Sie die Steckverbindungen des Temperatursensors, den Stecker des Ventilators und des Entlüfters an.

RU Подсоединить разъемы датчика температуры, разъем вентилятора и сапуна вентилятора.

EN As branch pipes are movable when being higher than the luggage rack platform due to adjustment of the relocation kit by inclination angle, please prevent touching of branch pipes and the hood and the luggage rack platform in order not to allow their abrasion.

DE Da die Stützen über dem Gepäckraum wegen der Einstellung der Austragung je nach dem Anstellungswinkel beweglich sind, müssen sie mit der Haube und dem Gepäckraum nicht berühren, um deren Scheuern zu vermeiden.

RU Так как выше багажной площадки патрубки подвижны из-за регулировки выноса по углу наклона, необходимо исключить касание патрубков с капотом и багажной площадки, во избежание их перетирания.

EN Install the radiator relocation kit in the highest lifted position, add antifreeze liquid and bleed the system.

DE Stellen Sie die Austragung des Kühlers in die höchstzulässige angehobene Position ein, gießen Sie Frostschutzmittel ein und entlüften Sie das System.

RU Установить вынос радиатора в максимально поднятое положение, залить антифриз, прокачать систему.