

## CF MOTO X4 CF400 AU-L

**No.:** 2444.6868.1  
**Brend:** CF MOTO  
**Model:** X4 CF400 AU-L  
**Year:** 2016-  
**Material:** Al - 4 mm



### Content

1. Plate 1.....	1 pc	15. Bolt M6x10.....	4 pc
2. Plate 2.....	1 pc	16. Bolt M6x20.....	16 pc
3. Plate 3.....	1 pc	17. Bolt M6x35.....	6 pc
4. Front arm guard.....	2 pc	18. Bolt M8x25.....	12 pc
5. Front arm guard.....	2 pc	19. Screw M8x20.....	2 pc
6. Rear arm guards.....	2 pc	20. Washer 6.....	8 pc
7. Bracket.....	1 pc	21. Washer 8.....	8 pc
8. Bracket.....	1 pc	22. Countersunk washer 6....	24 pc
9. Bracket.....	2 pc	23. Countersunk washer 8....	6 pc
10. Bracket.....	1 pc	24. Round-head bolt.....	6 pc
11. Bracket.....	2 pc	25. Nut M6.....	6 pc
12. Bracket.....	2 pc	26. Spring washer 6.....	6 pc
13. Bracket.....	4 pc	27. CV joint guards.....	2 pc
14. Spacer h-10 mm.....	4 pc	28. Spacer h-14 mm.....	2 pc

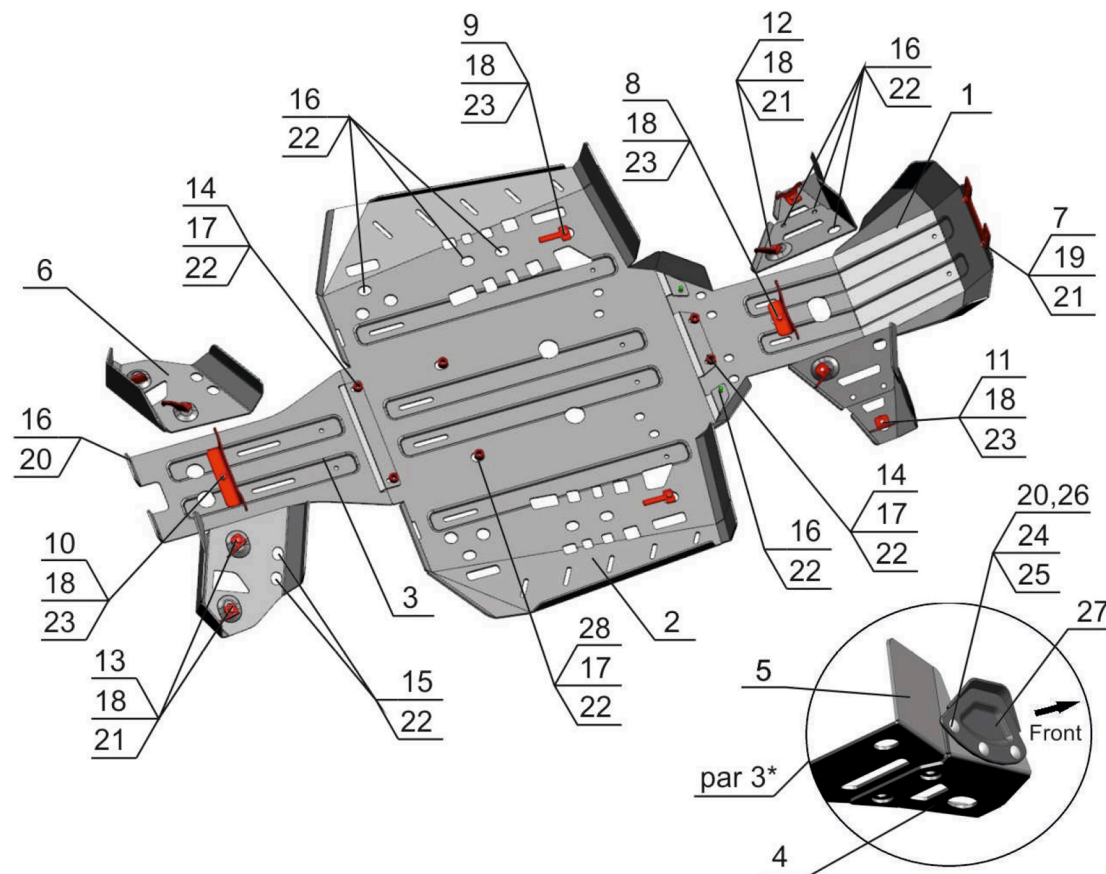

### Installation Instructions

1. Remove original plastic protection.
2. Fix rear end of plate no.3 to original threaded apertures with bolts no.16 and washers no.20. Fix front end of plate no.3 to original threaded apertures with bolts no.17 and washers no.22 through spacers no.14. Place bracket no.10 on plate no.3, as shown on the picture, then fix them with bolts no.18, washers no.23.
- 3\*. Fix CV joint guards no.27 to front arm guards no.4, no.5, as shown on the picture, with bolts no.24, washers no.20, no.26 and nuts no.25. Fix front arm guards no.4, no.5 to original threaded apertures and brackets no.11, no.12 with bolts no.16, no.18 and washers no.21, no.22, no.23.
4. Fix rear arm guards no.6 to original threaded apertures and brackets no.13 with bolts no.15, no.18 and washers no.21, no.22.

5. Place rear end of plate no.2 under mounted nuts no.22 at the interface of plate no.3. Fix plate no.2 to brackets no.9 and original threaded apertures with bolts no.16, no.27, no.18 and washers no.22, no.23, use spacers no.14, no.28 in the front and middle part of plate no.2.
6. Fix bracket no.7 under a roller fairlead with original bolts. Place rear end of plate no.1 under mounted nuts no.22 at the interface of plate no.2. Fix plate no.1 to brackets no.7, no.8 and rivet nuts of plate no.2 with bolts no.16, no.18, screws no.19 and washers no.21, no.22, no.23.
7. Tighten all screws.

**TOOLS REQUIRED**







S-10, S-13      S-5

**SCREW FORCE**



M6-10 Nm      M8-30 Nm      M10-50 Nm



**FRONT ARM GUARDS no. 24.6868.1-4**

<p><b>4</b></p>  <p>x 2</p>	<p><b>5</b></p>  <p>x 2</p>	<p><b>11</b></p>  <p>x 2</p>	<p><b>12</b></p>  <p>x 2</p>	<p><b>27</b></p>  <p>x 2</p>	<p>Bolt M6x20 - 6 pc          Bolt M8x25 - 4 pc          Washer 8 - 2 pc          Countersunk washer 6 - 6 pc          Countersunk washer 8 - 2 pc          Spring washer 6 - 6 pc          Washer 6 - 6 pc          Blind head bolt - 6 pc          Nut M6 - 6 pc</p>
---	---	--	--	--	--



**REAR ARM GUARDS no. 24.6868.1-5**

<p><b>6</b></p>  <p>x 2</p>	<p><b>13</b></p>  <p>x 4</p>	<p>Bolt M8x25 - 4 pc          Bolt M6x10 - 4 pc          Washer 8 - 4 pc          Countersunk washer 6 - 4 pc</p>
--	---	---

**FRONT REDUCER GUARD no. 24.6868.1-1**

<p><b>1</b></p>  <p>x 1</p>	<p><b>7</b></p>  <p>x 1</p>	<p><b>8</b></p>  <p>x 1</p>	<p>Bolt M6x20 - 2 pc          Bolt M8x25 - 1 pc          Screw M8x20 - 2 pc          Washer 8 - 4 pc          Countersunk washer 6 - 2 pc          Countersunk washer 8 - 1 pc</p>
--	--	--	--

**ENGINE BLOCK GUARD no. 24.6868.1-2**

<p><b>2</b></p>  <p>x 1</p>	<p><b>9</b></p>  <p>x 2</p>	<p>Bolt M6x20 - 6 pc          Bolt M6x35 - 4 pc          Bolt M8x25 - 2 pc          Countersunk washer 6 - 10 pc          Countersunk washer 8 - 2 pc          Spacer h-10 mm - 2 pc          Spacer h-14 mm - 2 pc</p>
--	--	---

**BACK REDUCER GUARD no. 24.6868.1-3**

<p><b>3</b></p>  <p>x 1</p>	<p><b>10</b></p>  <p>x 1</p>	<p>Bolt M6x20 - 2 pc          Bolt M6x35 - 2 pc          Bolt M8x25 - 1 pc          Washer 6 - 2 pc          Countersunk washer 6 - 2 pc          Countersunk washer 8 - 1 pc          Spacer h-10 mm - 2 pc</p>
---	--	--