

EN

**UNIVERSAL SNOW BLADE MOUNTING PAD
INSTALLATION MANUAL**

RU

**ИНСТРУКЦИЯ ПО УСТАНОВКЕ КРЕПЛЕНИЯ
УНИВЕРСАЛЬНОГО СНЕГОТВАЛА**

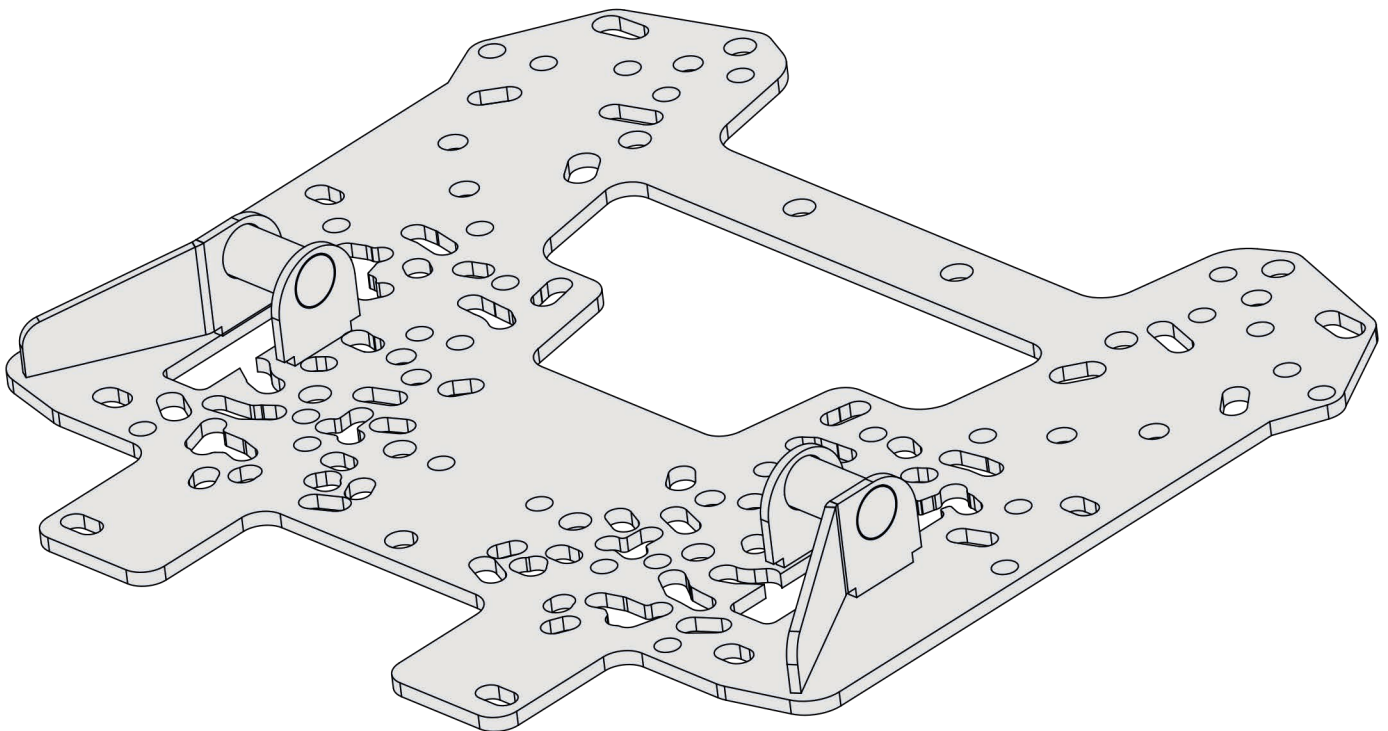

**RIVAL UNIVERSAL SNOW BLADE MOUNTING PAD
УНИВЕРСАЛЬНОЕ КРЕПЛЕНИЕ СНЕГОТВАЛА RIVAL**

444.0038.1

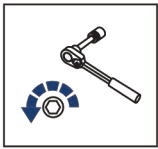

EN Regular fasteners
DE Originale montageteile
RU Штатный крепеж

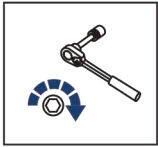

EN Regular fasteners
DE Originale montageteile
RU Штатный крепеж



EN Screw a several turns
DE Für wenigen Umdrehungen befestigen
RU Вкрутить на несколько оборотов



EN Loosen bolts
DE Bolzen lockern
RU Выкрутить на несколько оборотов

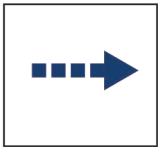

EN Movement Arrow
DE Bewegungsrichtung
RU Движение

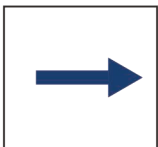

EN Location/Position Arrow
DE Anordnung/Positionsrichtung
RU Расположение



EN Screw Arrow
DE Drehungsrichtung
RU Поворот



1

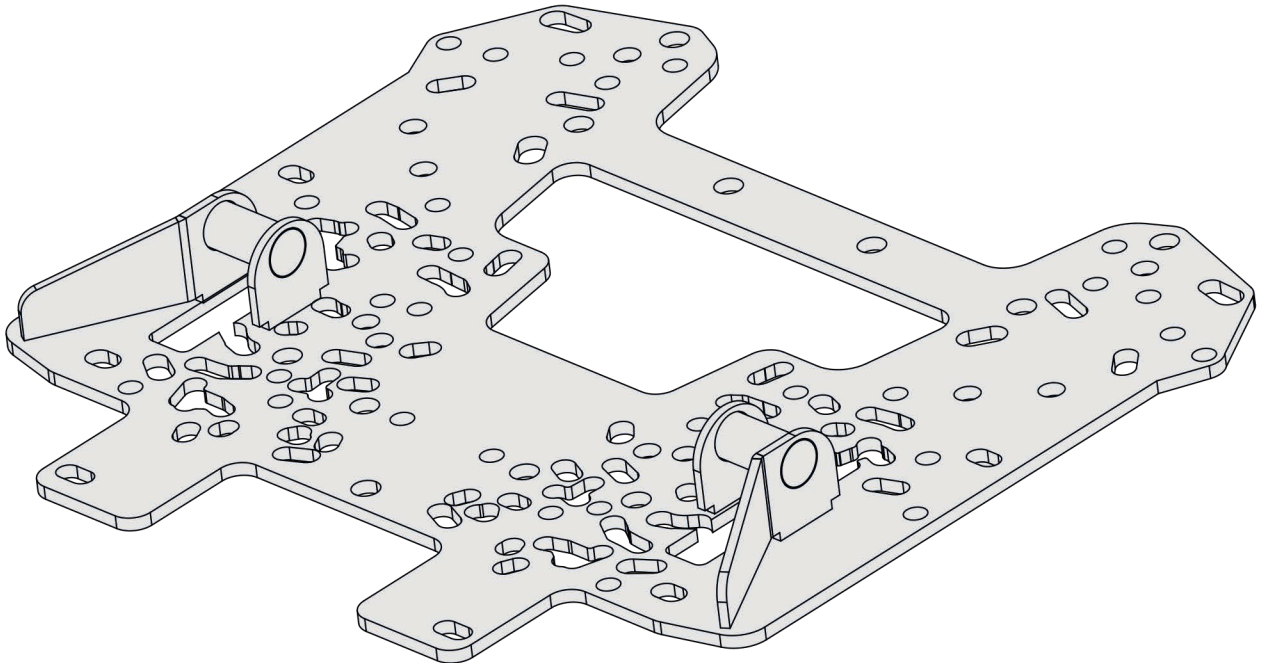

x1

2 x4	3 x4	4 x2	5 M6x30 x2	6 M8x20 x4	7 M8x35 x2
8 M8x80 x8	9 M10x35 x3	10 ø6 x2	11 ø8 x4	12 ø8 x8	13 ø10 x3
14 M8x65/15 x2	15 M10x65/35,5 x1	16 M10x105/35 x2	17 M8 x8		

Универсальное крепление снегоотвала / Universal snow blade mounting pad

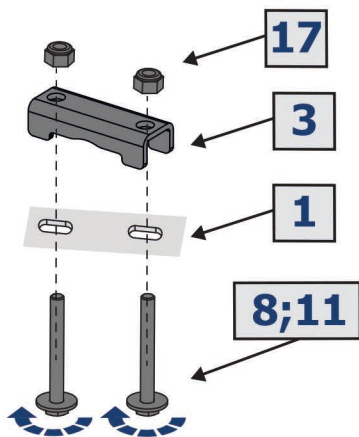
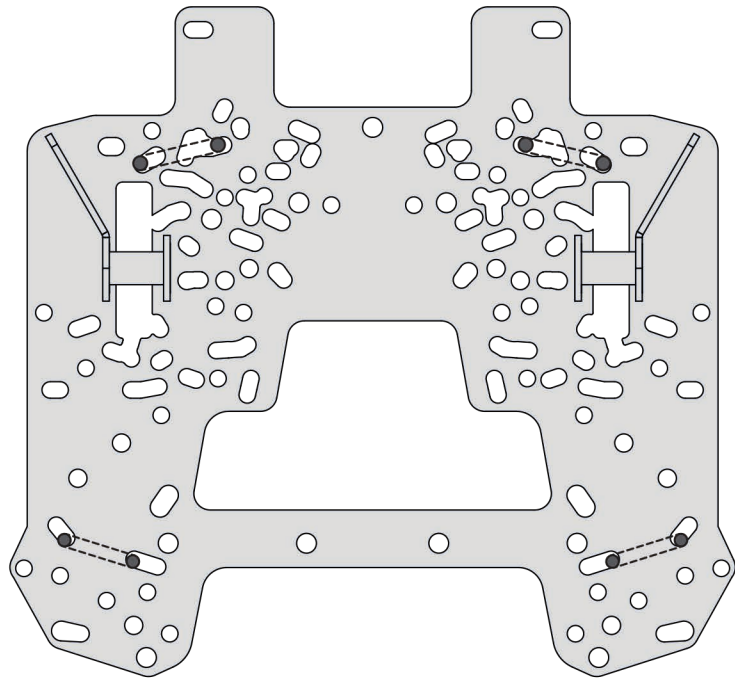
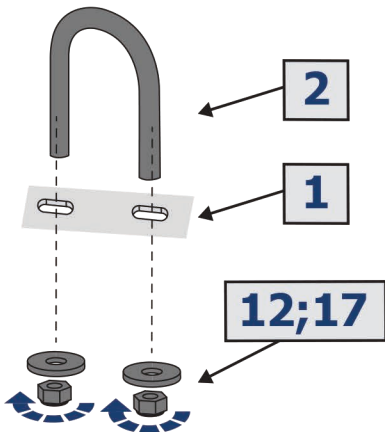

RM 500

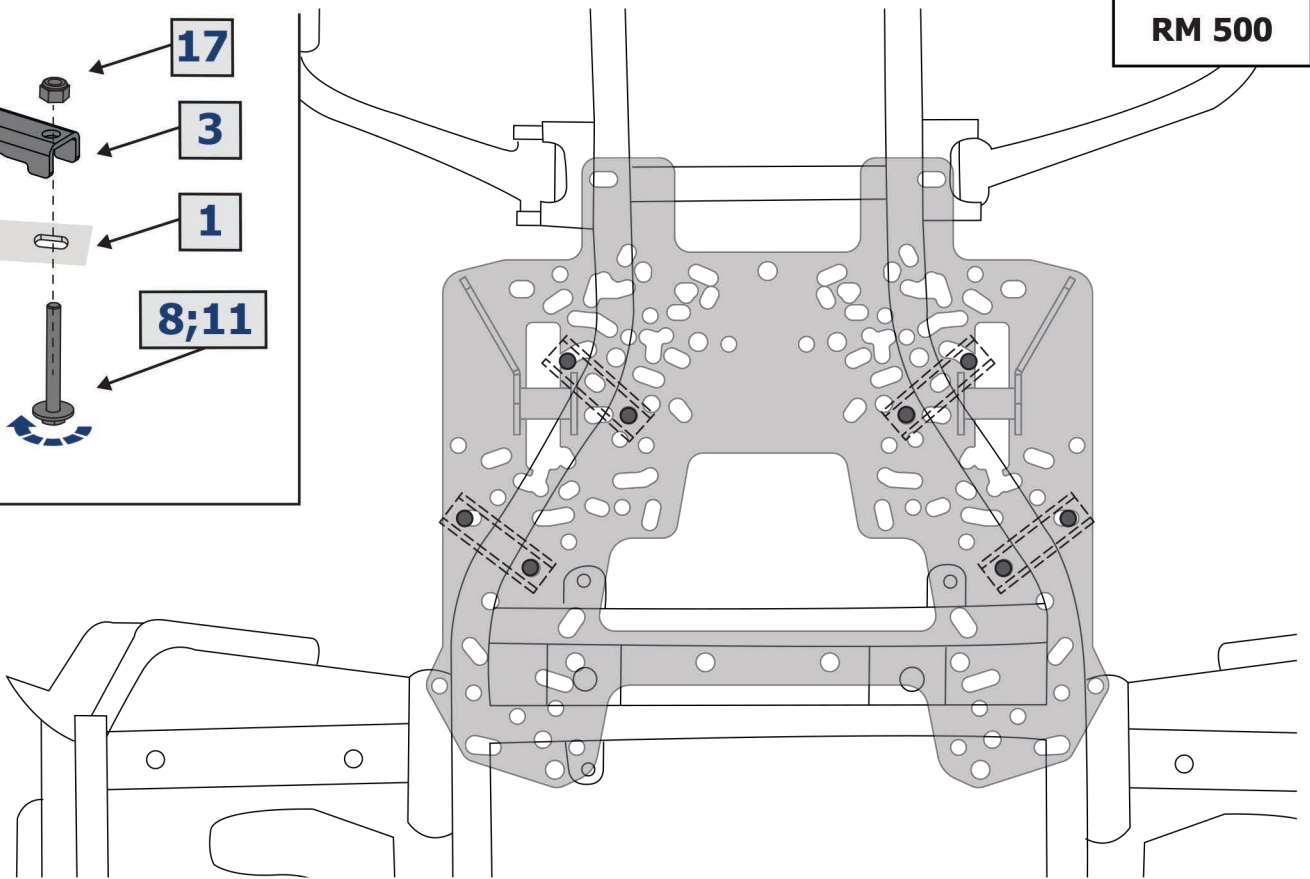

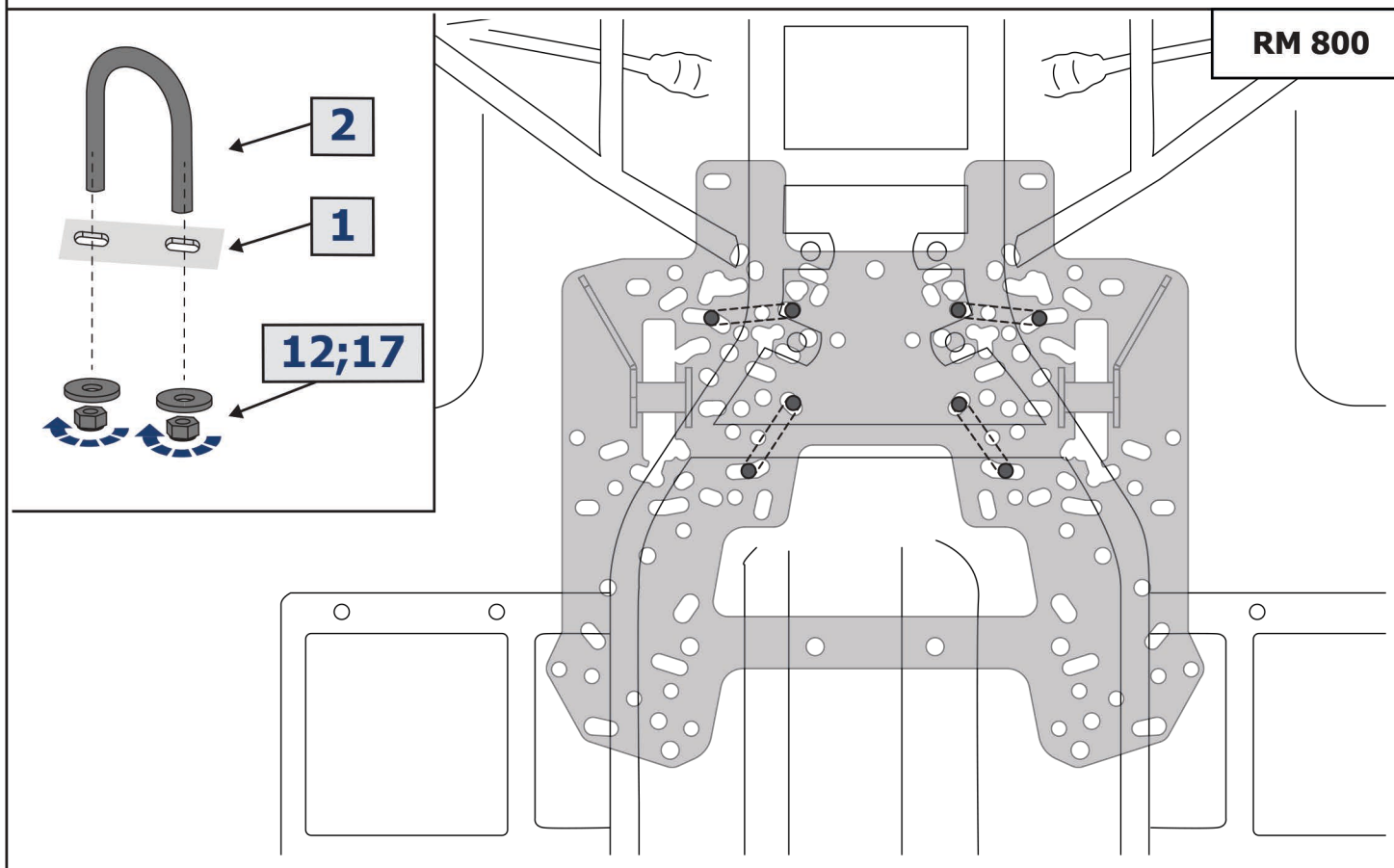
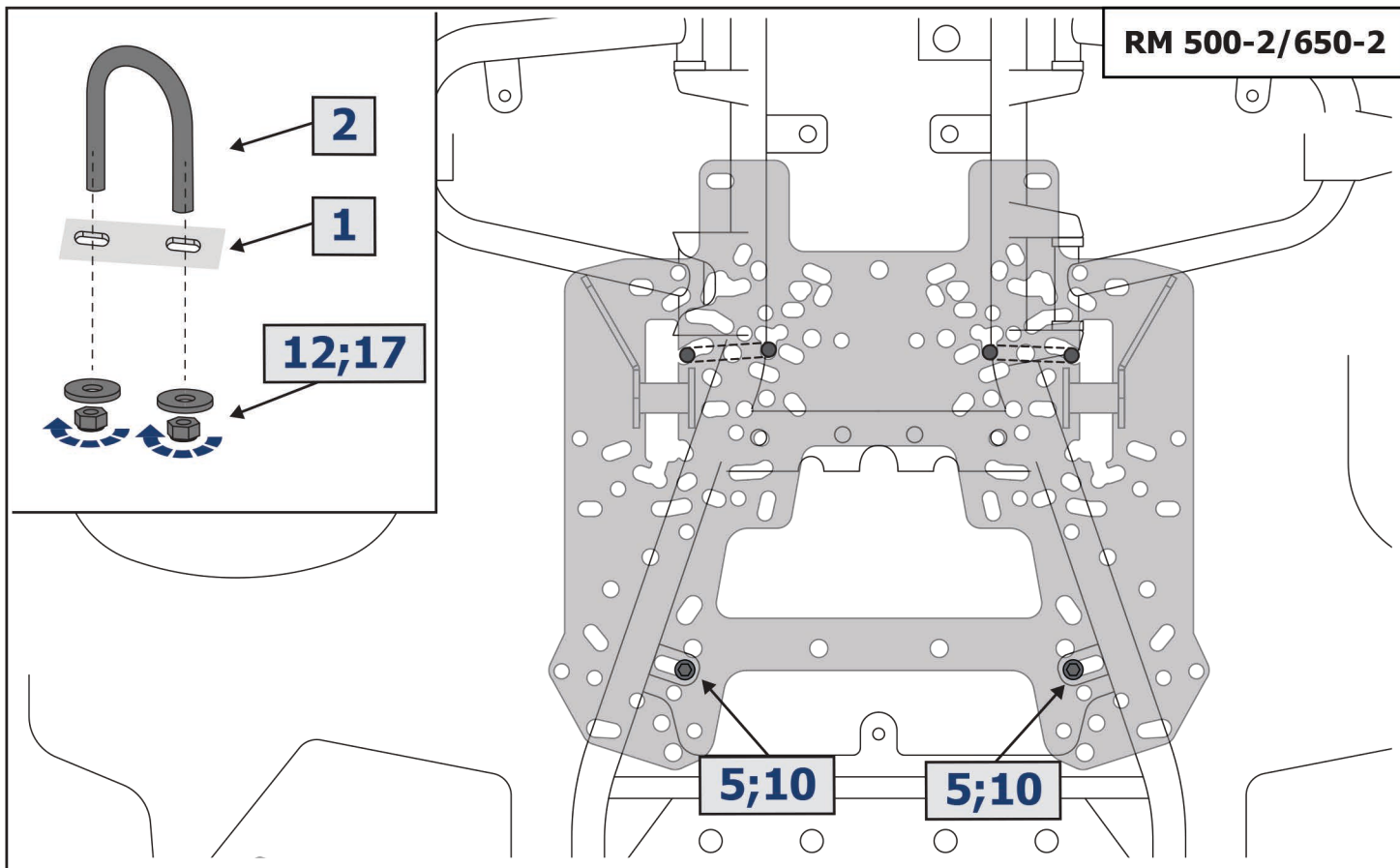

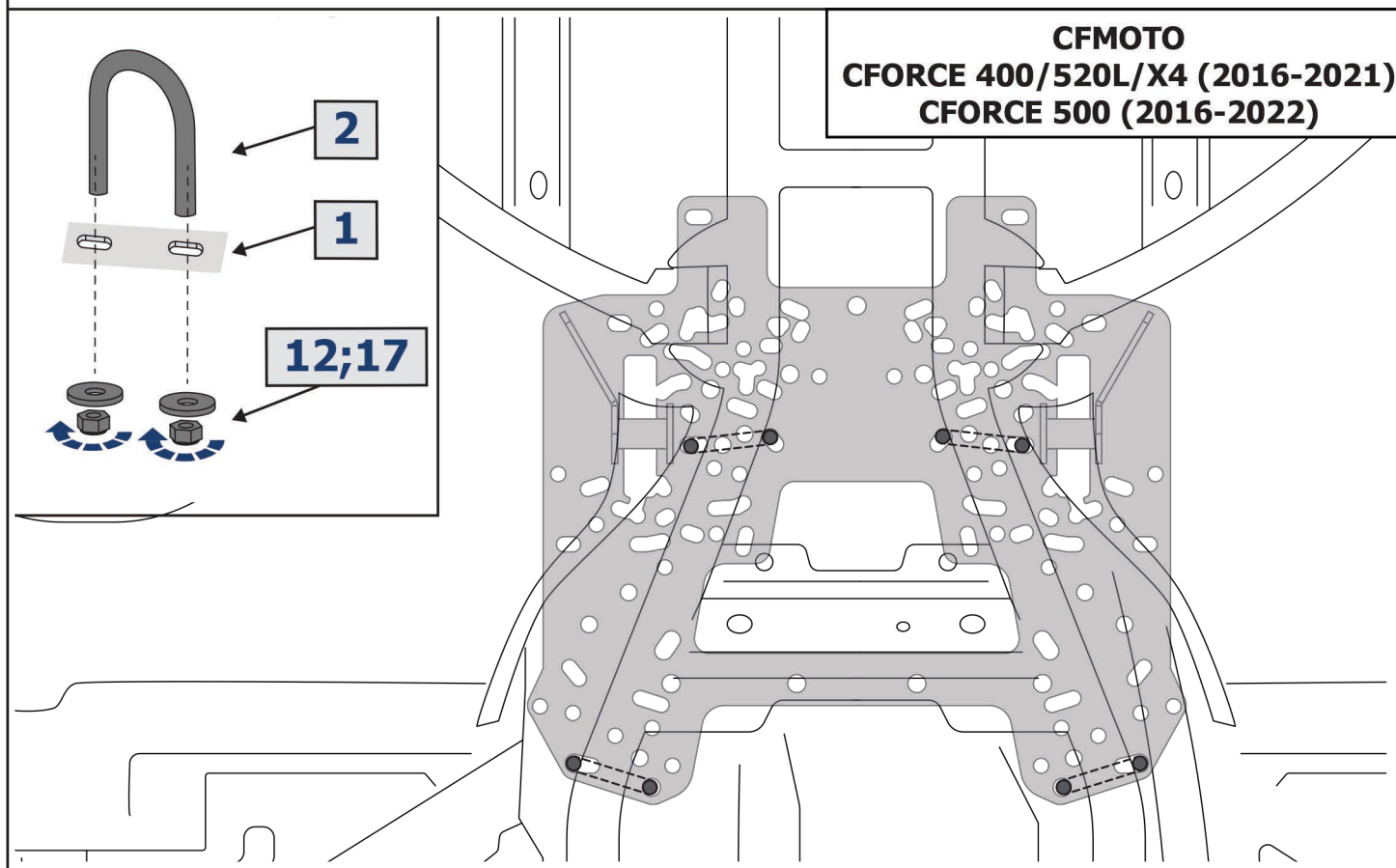
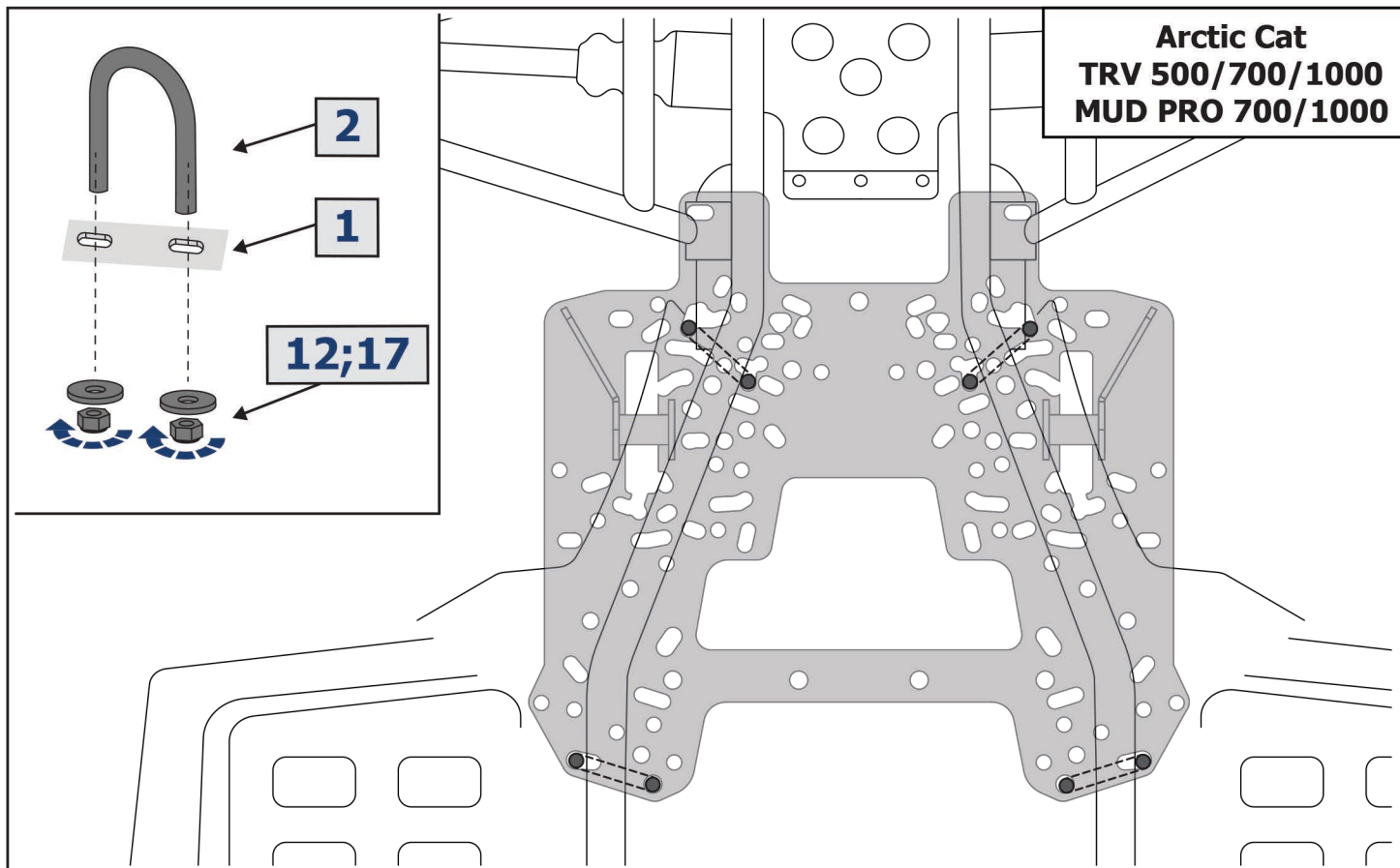

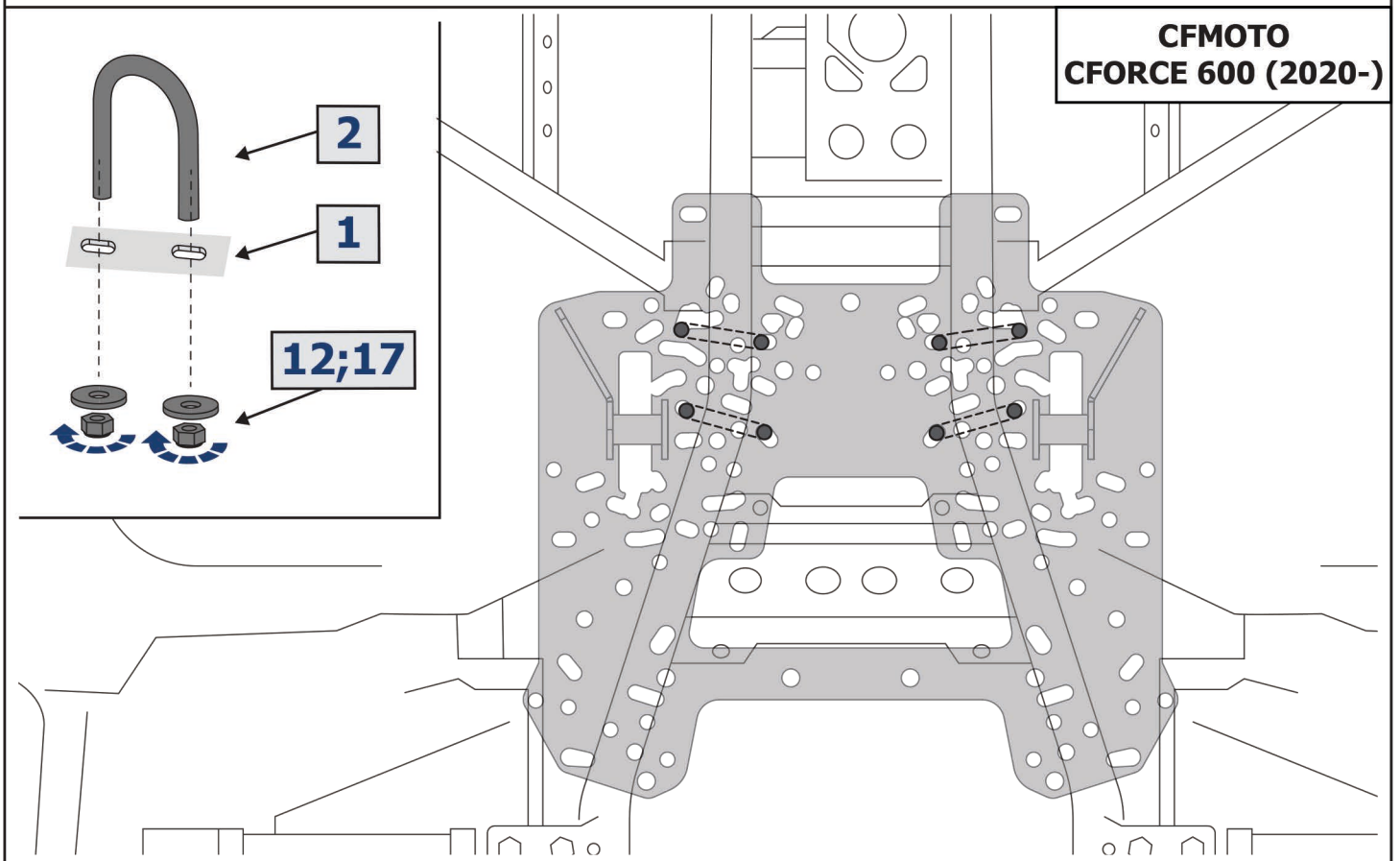
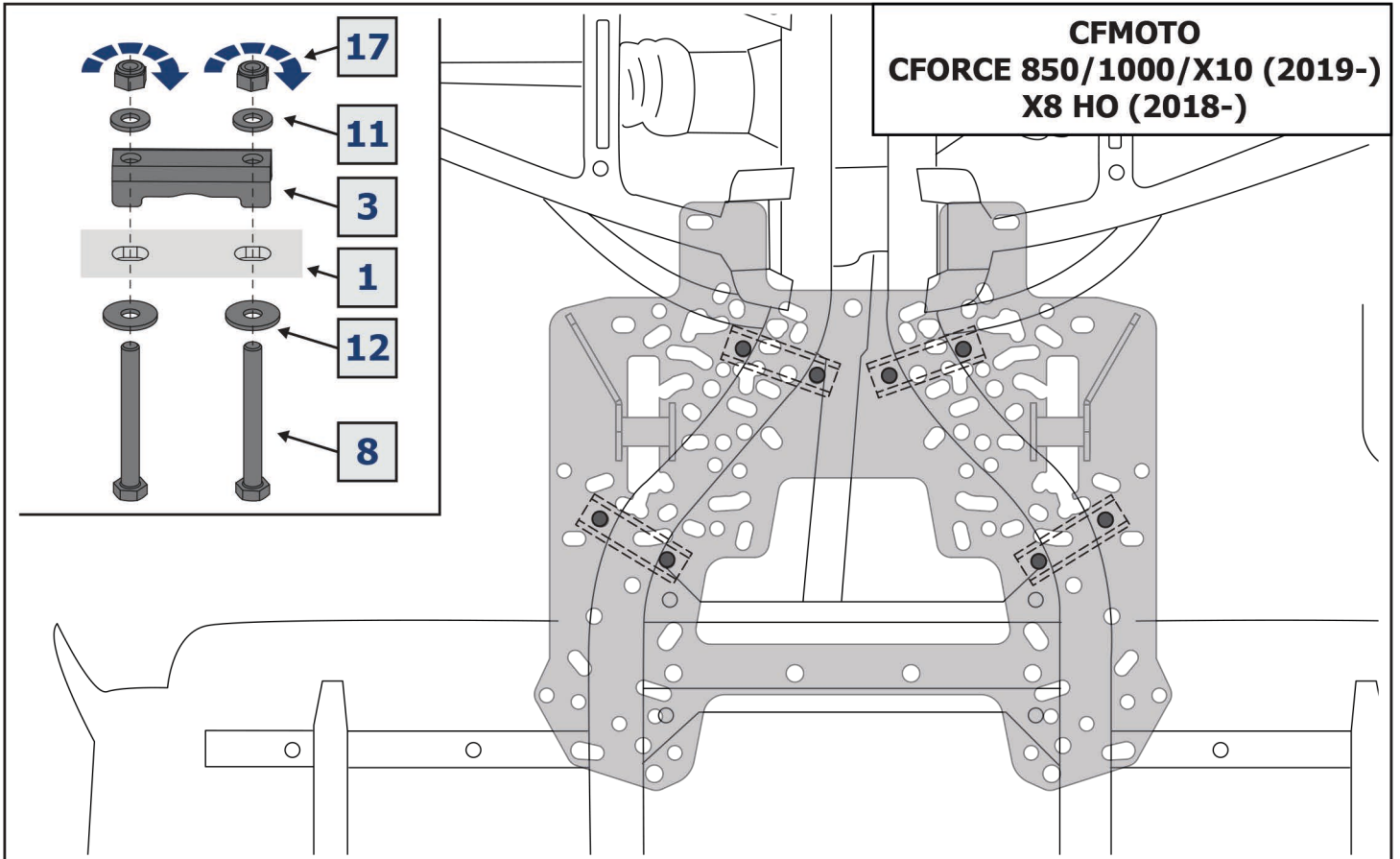

**CFMOTO
CFORCE 450/520 (2022-)**

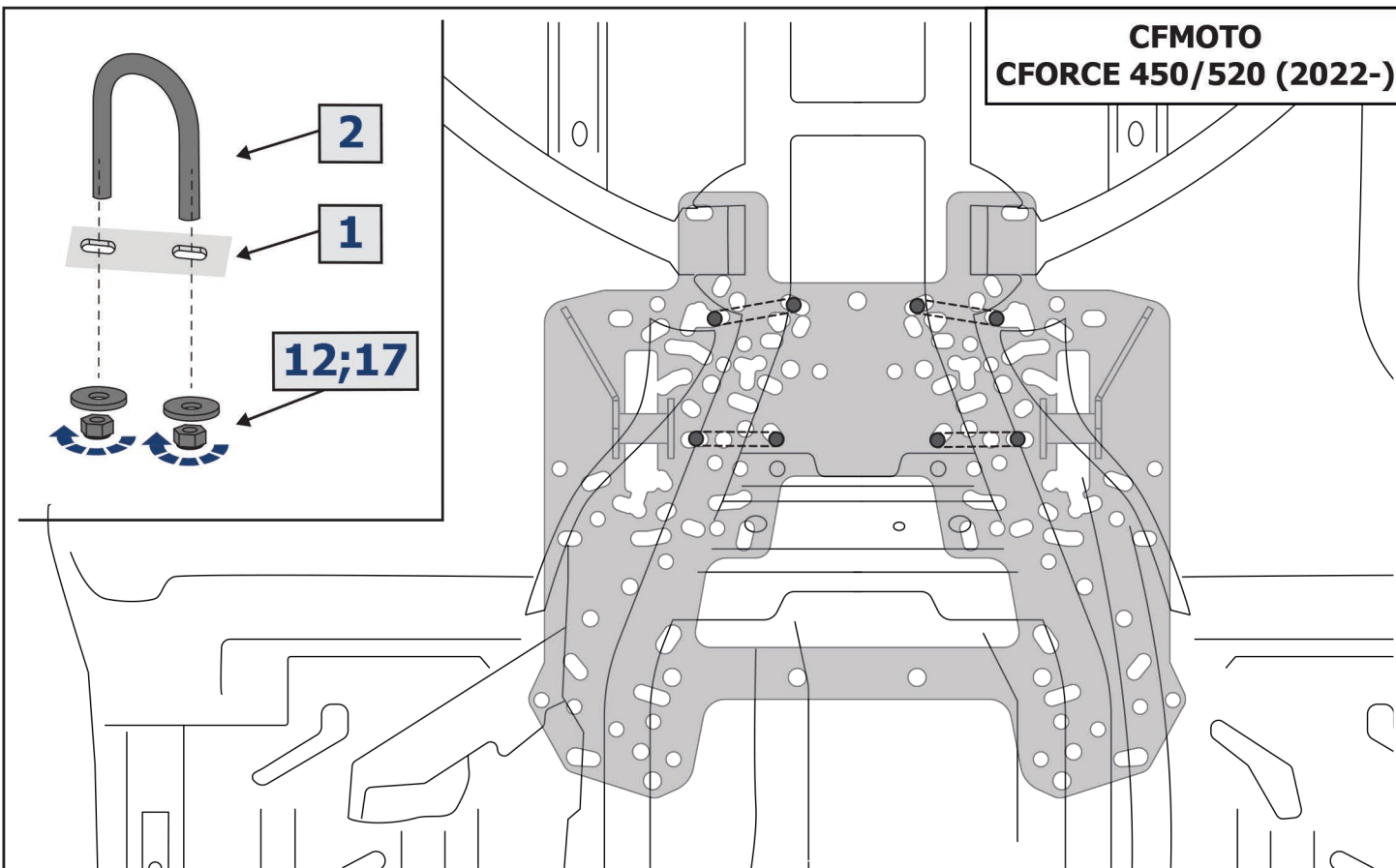

**CFMOTO
CFORCE 800/820
X8 (2013-2017)**

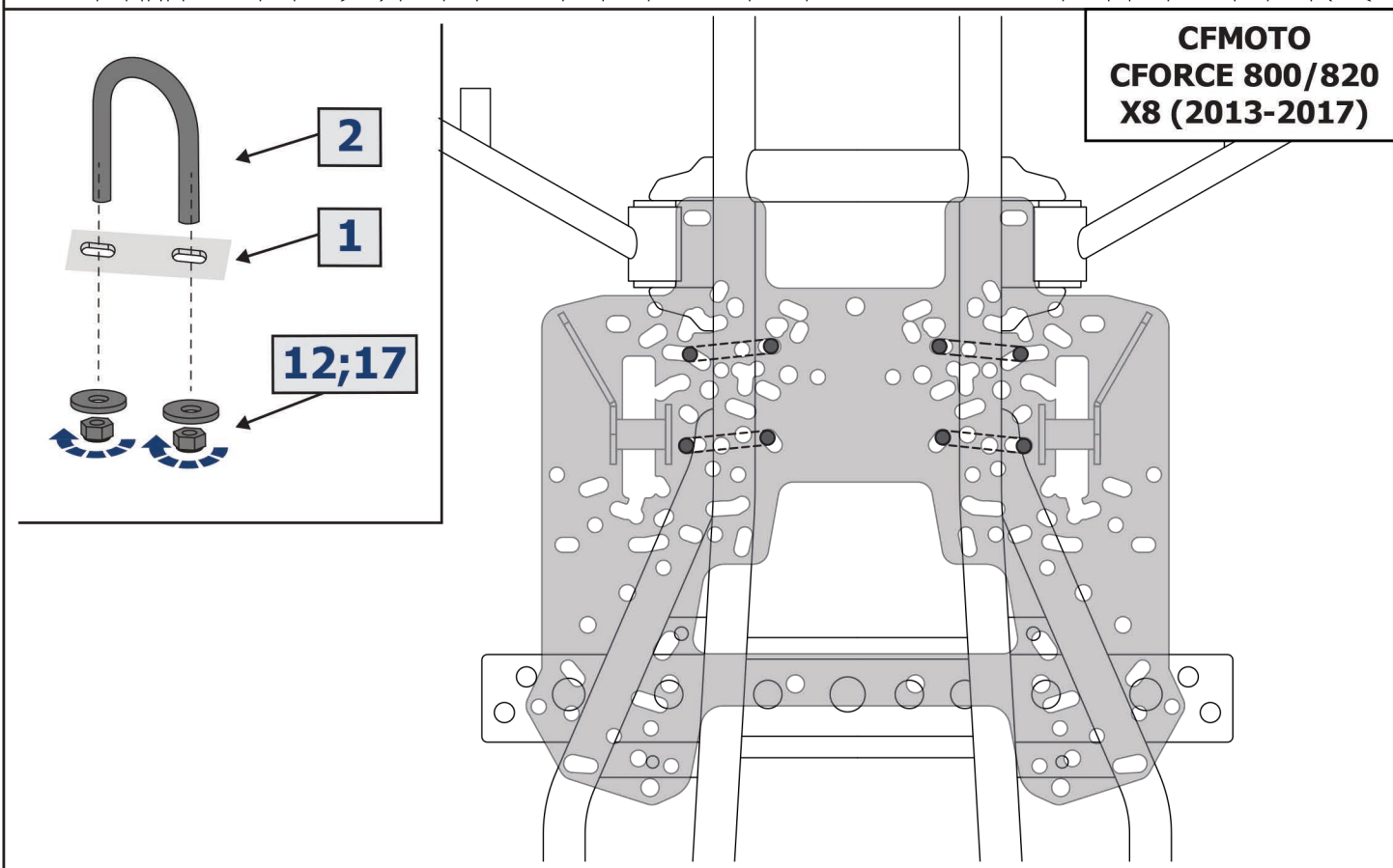

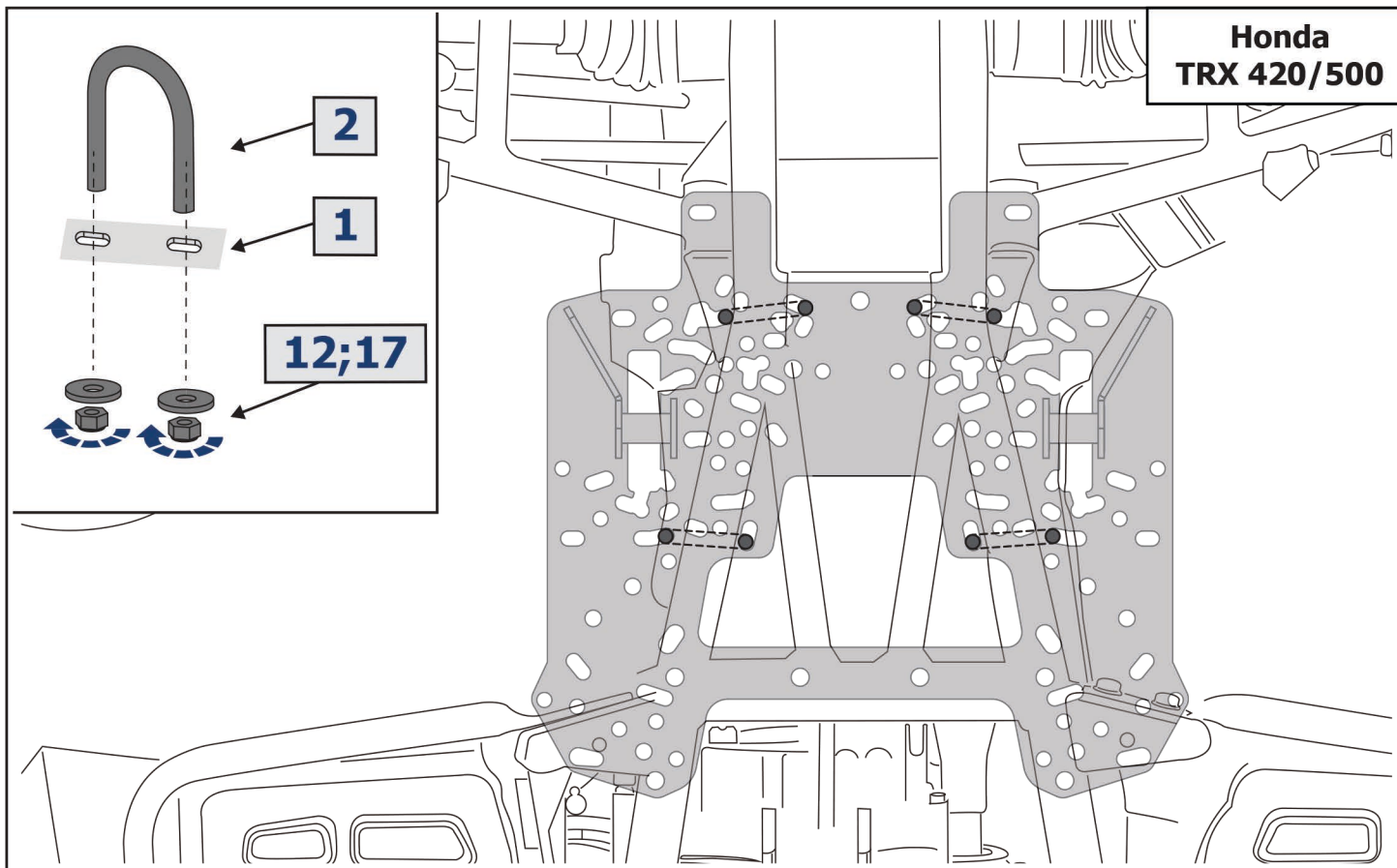
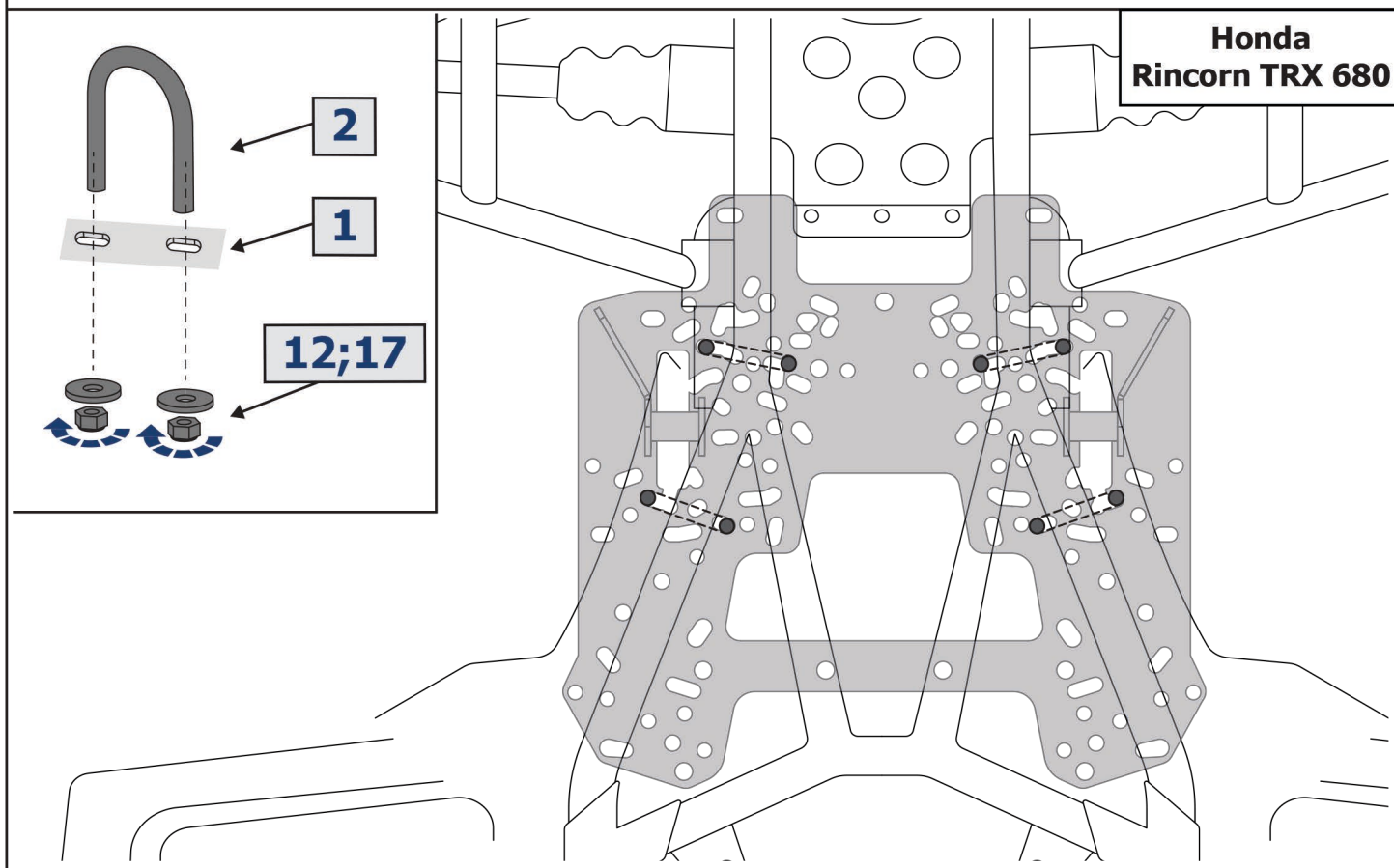
**Honda
TRX 420/500****Honda
Rincorn TRX 680**

**Kawasaki
KVF 750**

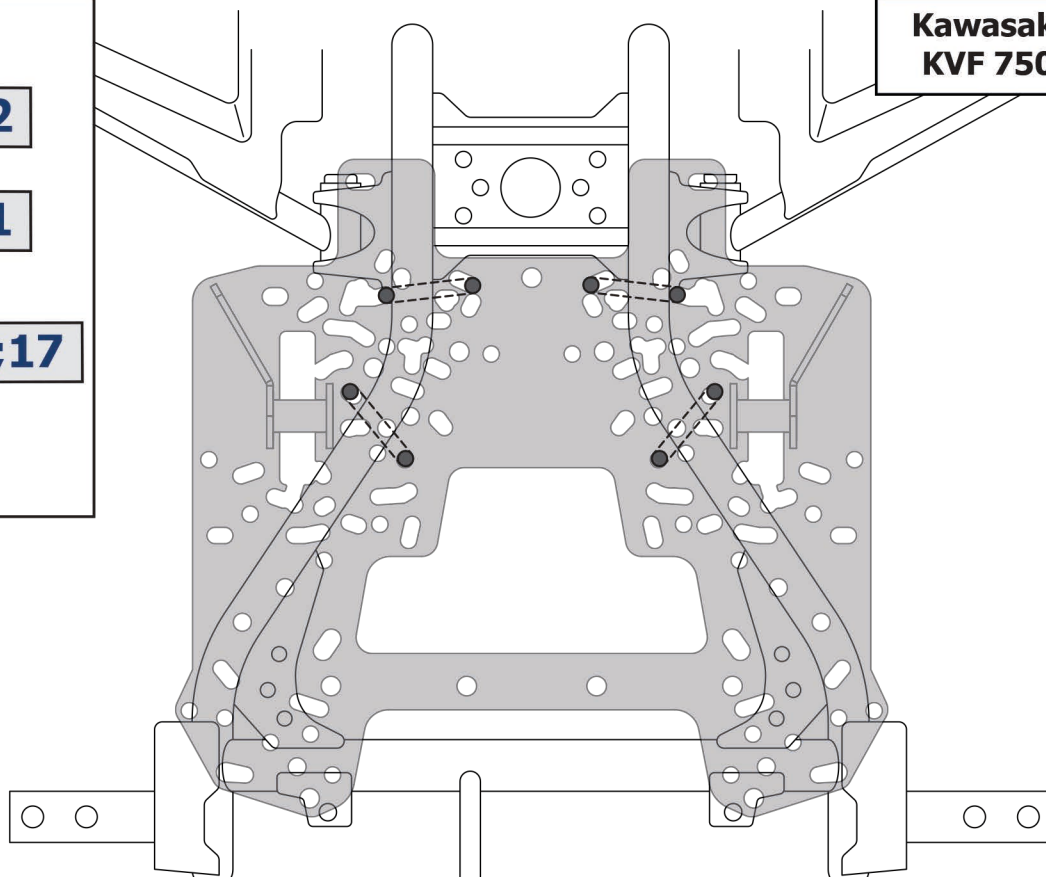
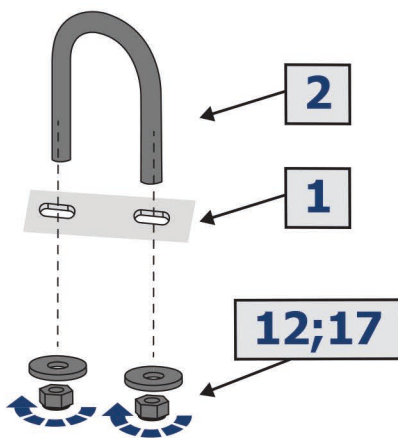

**Polaris
Scrambler 1000**

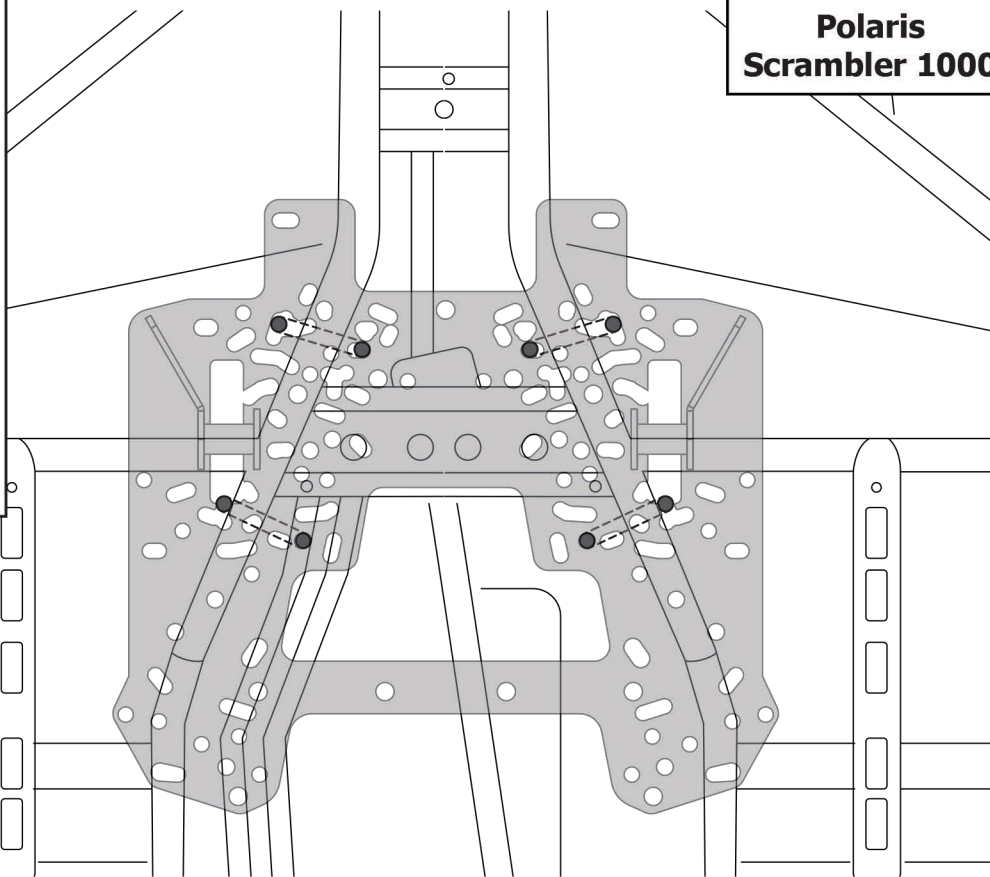
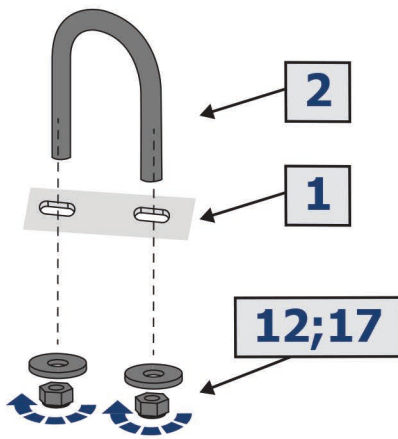

**Polaris
Sportsman 850**

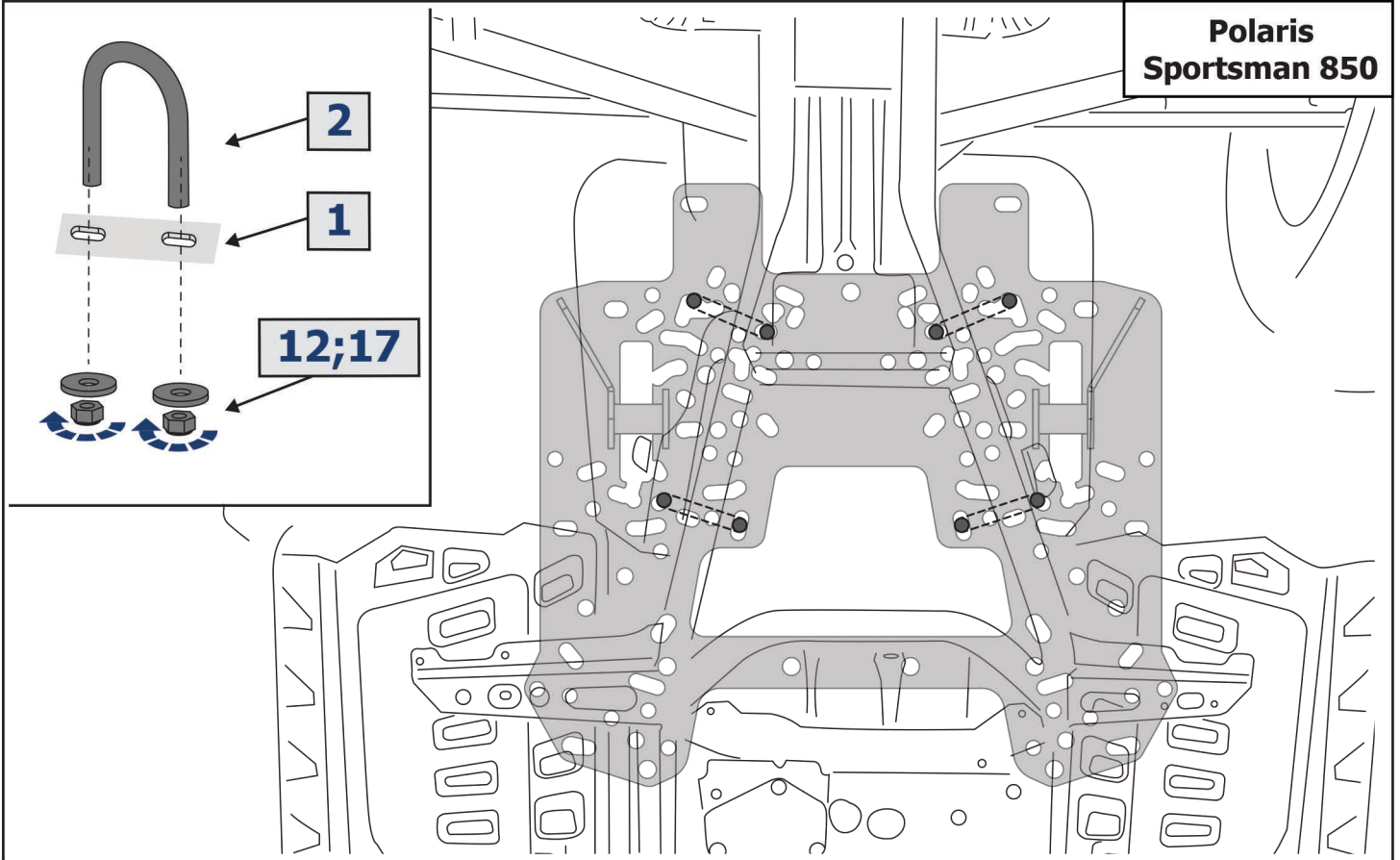

**Suzuki
KingQuad 750**

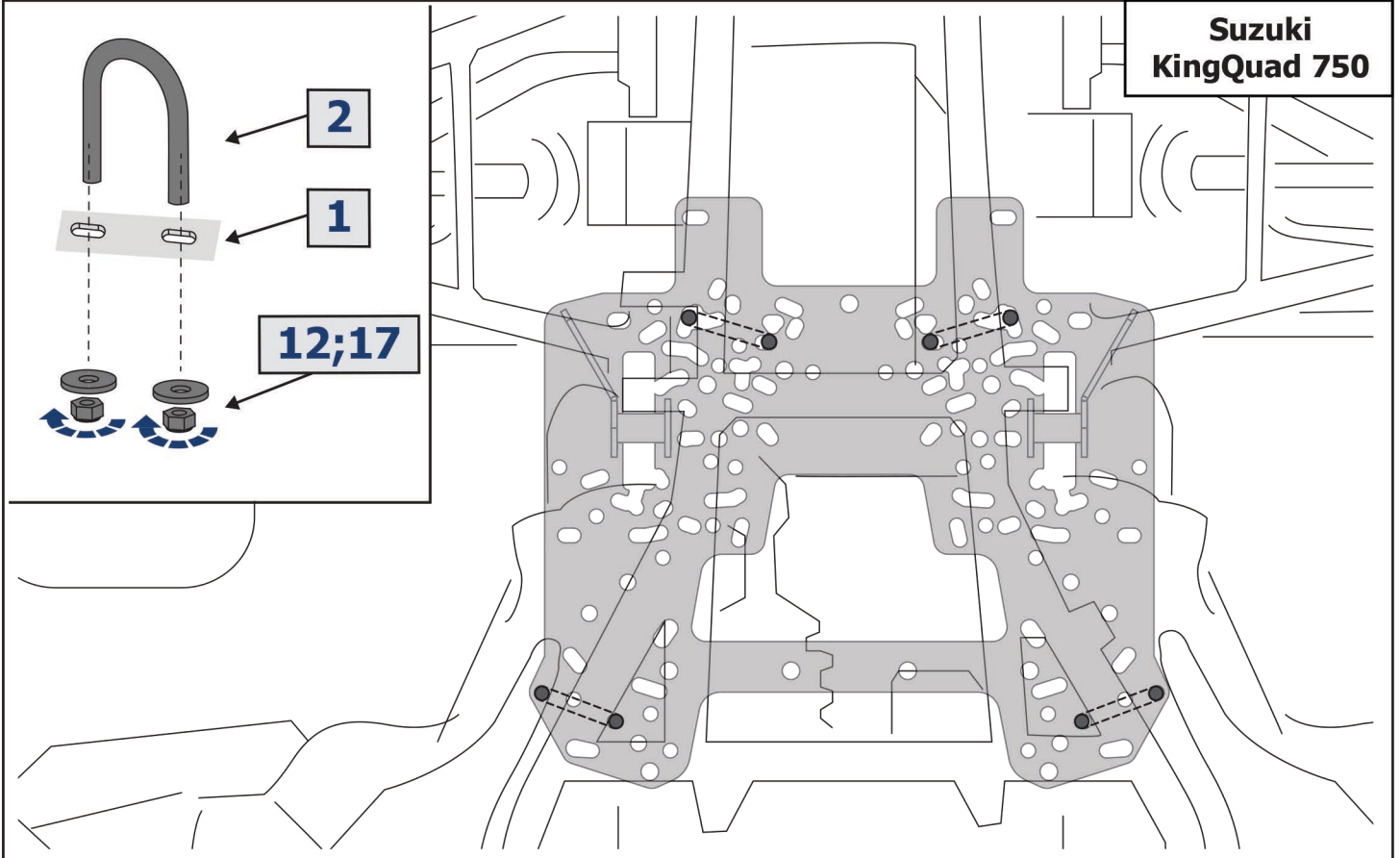

**Yamaha
Grizzly 350/450**

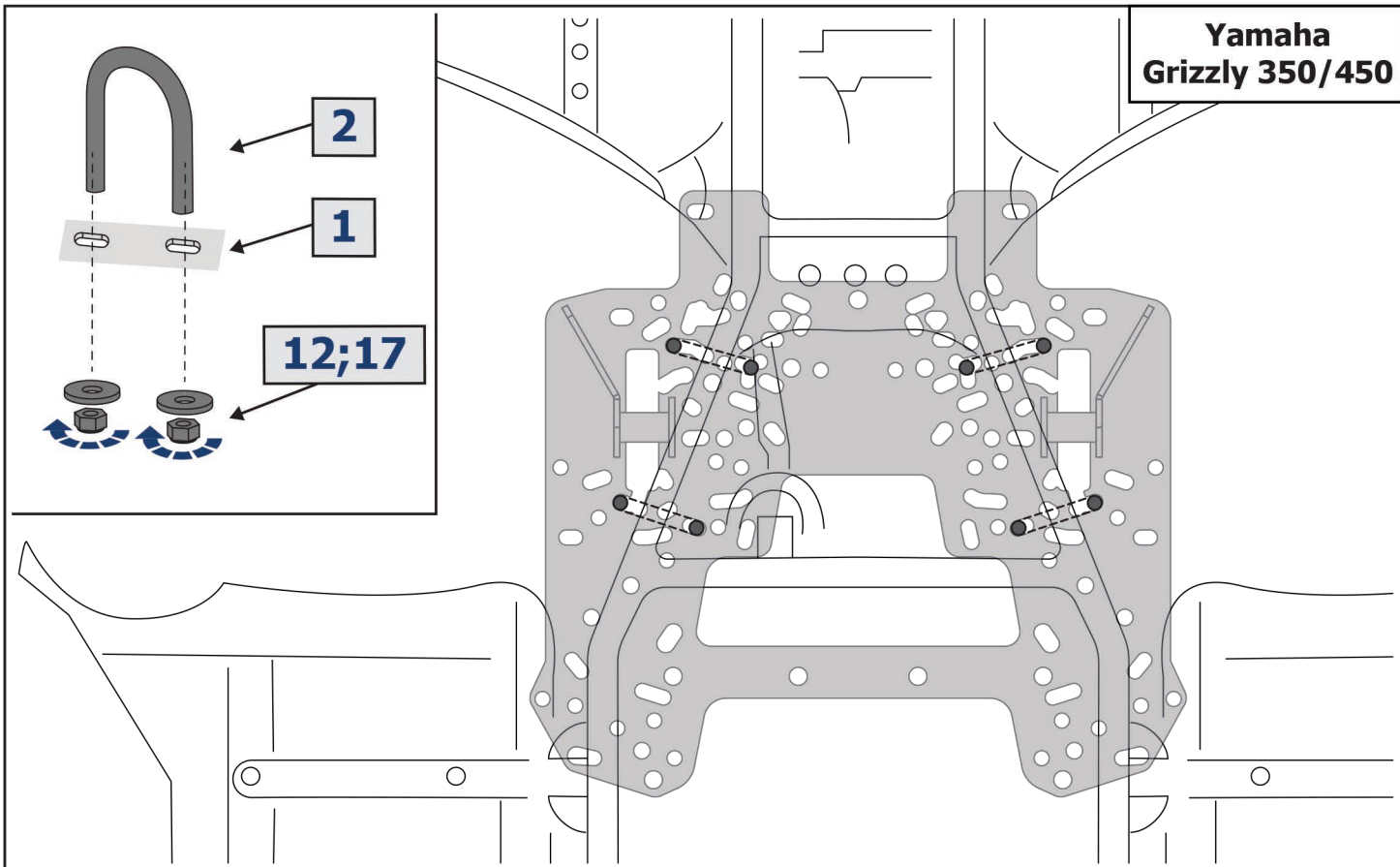

**Yamaha
Grizzly 550/700
Kodiak 700**

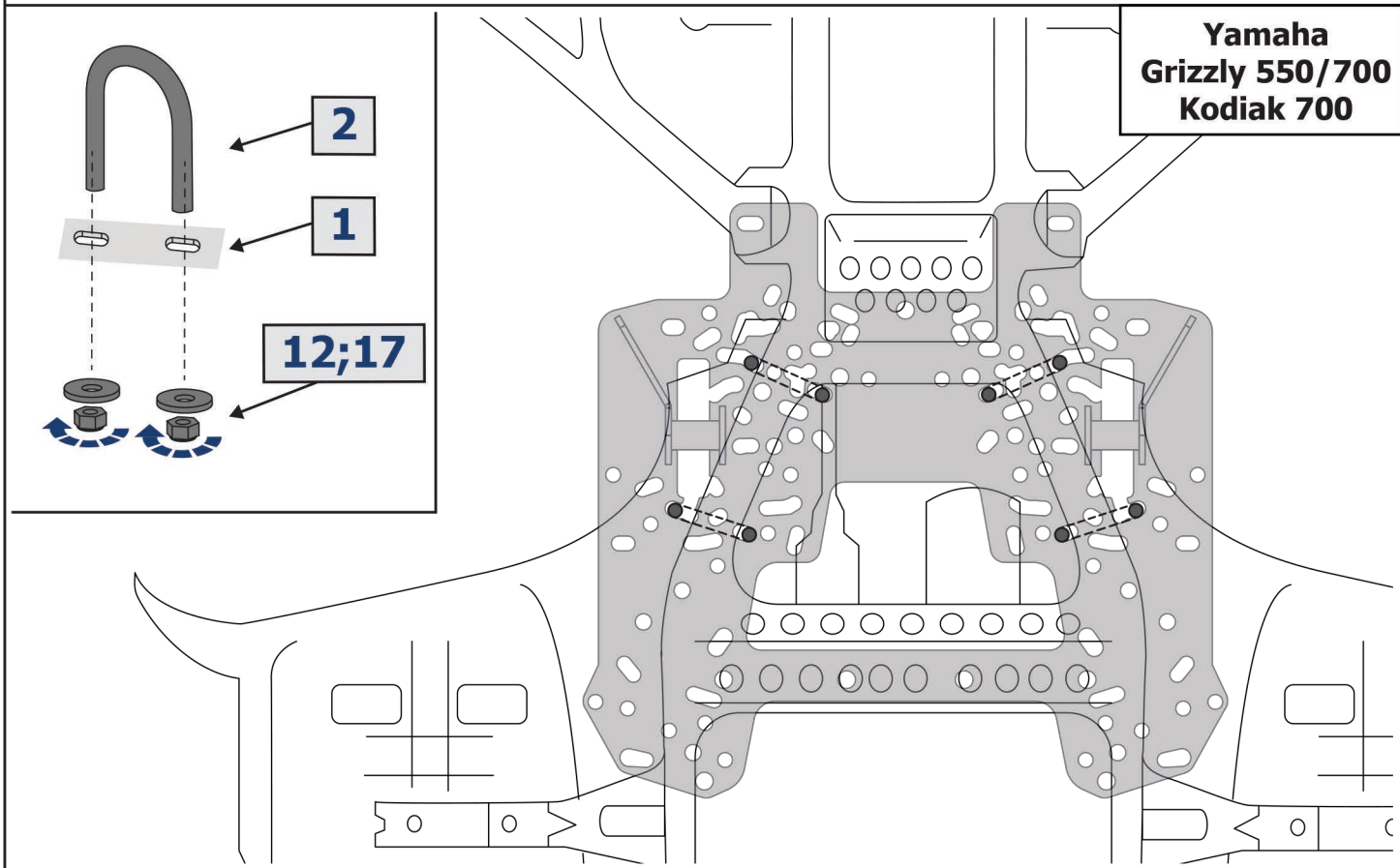

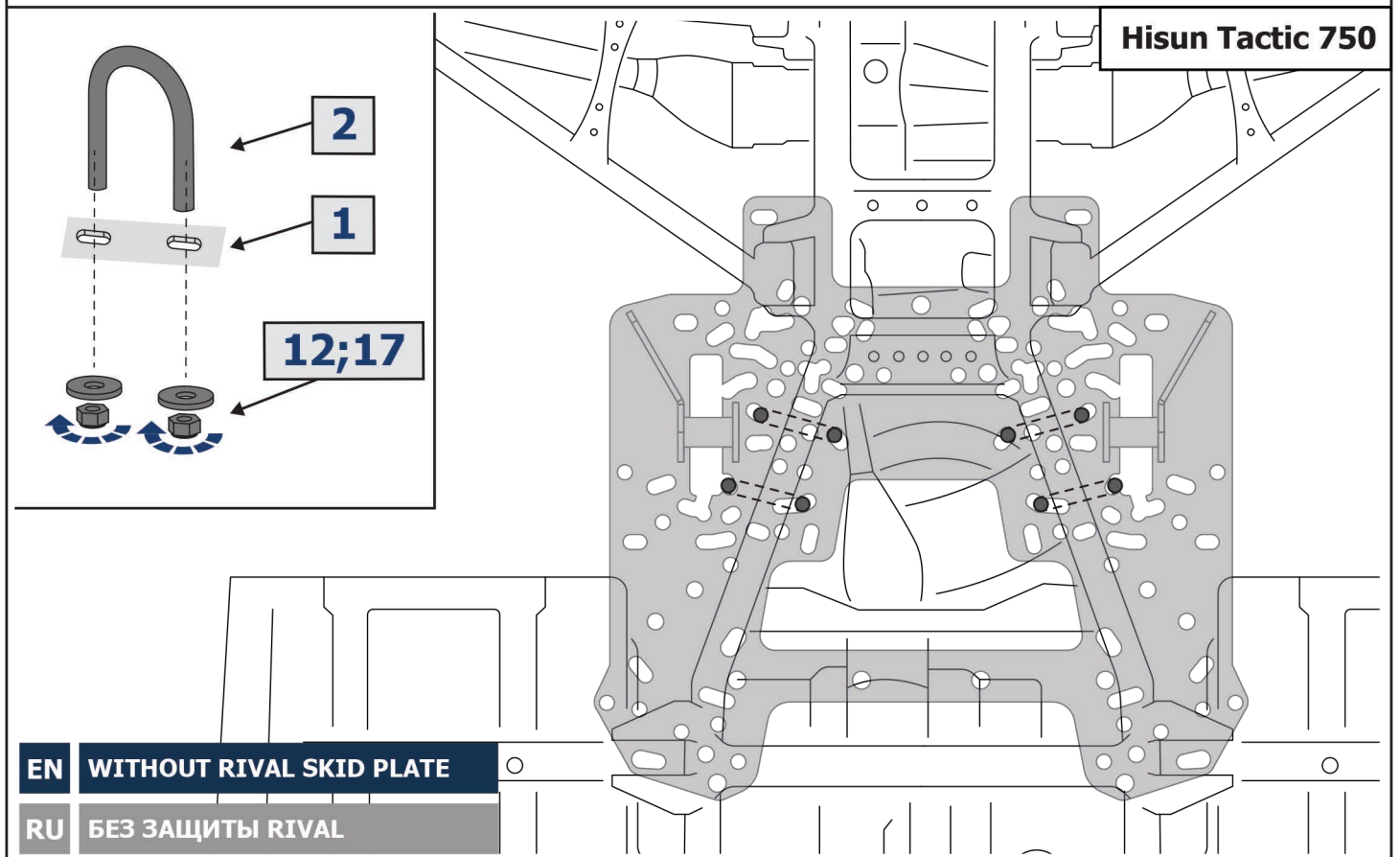
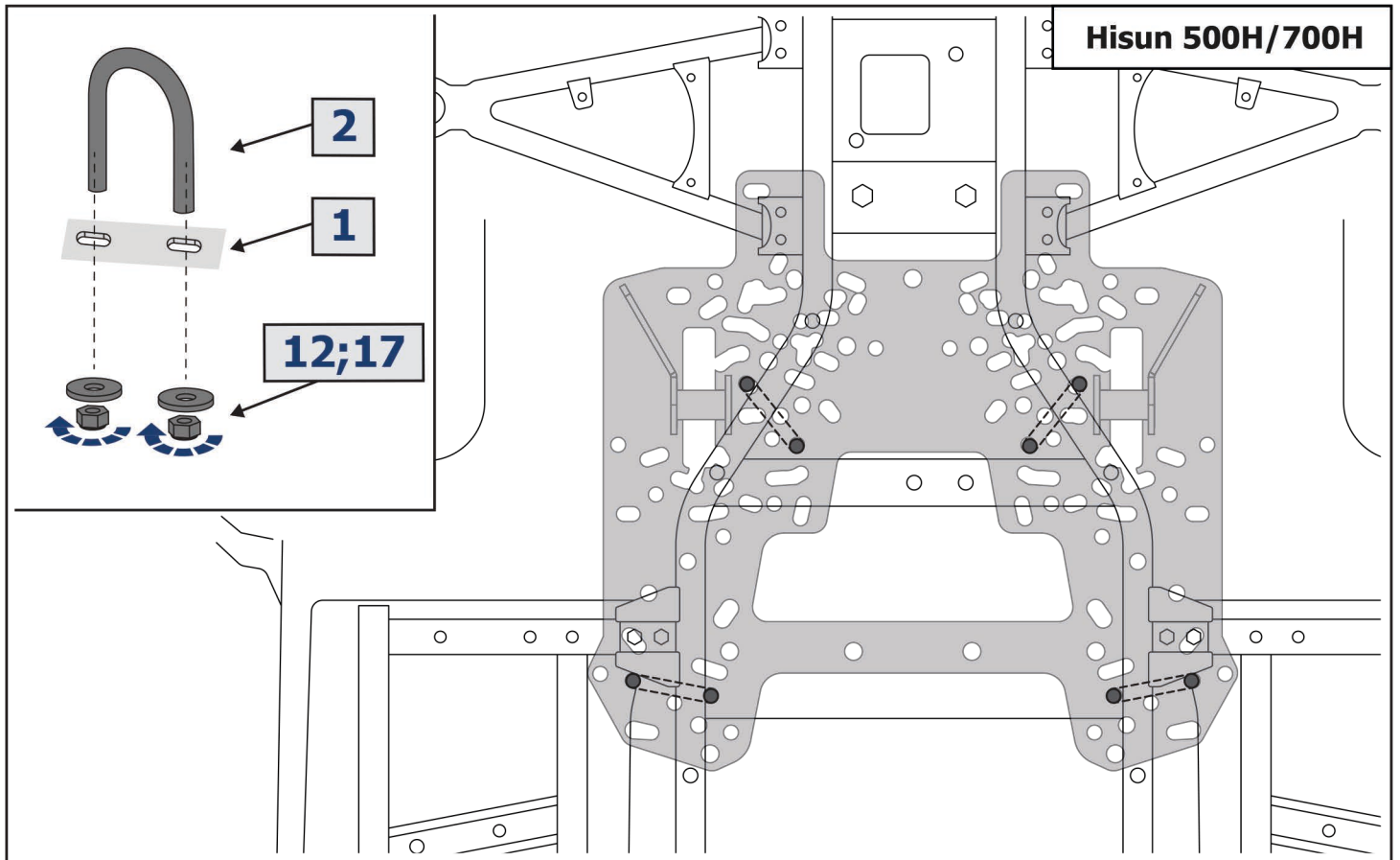

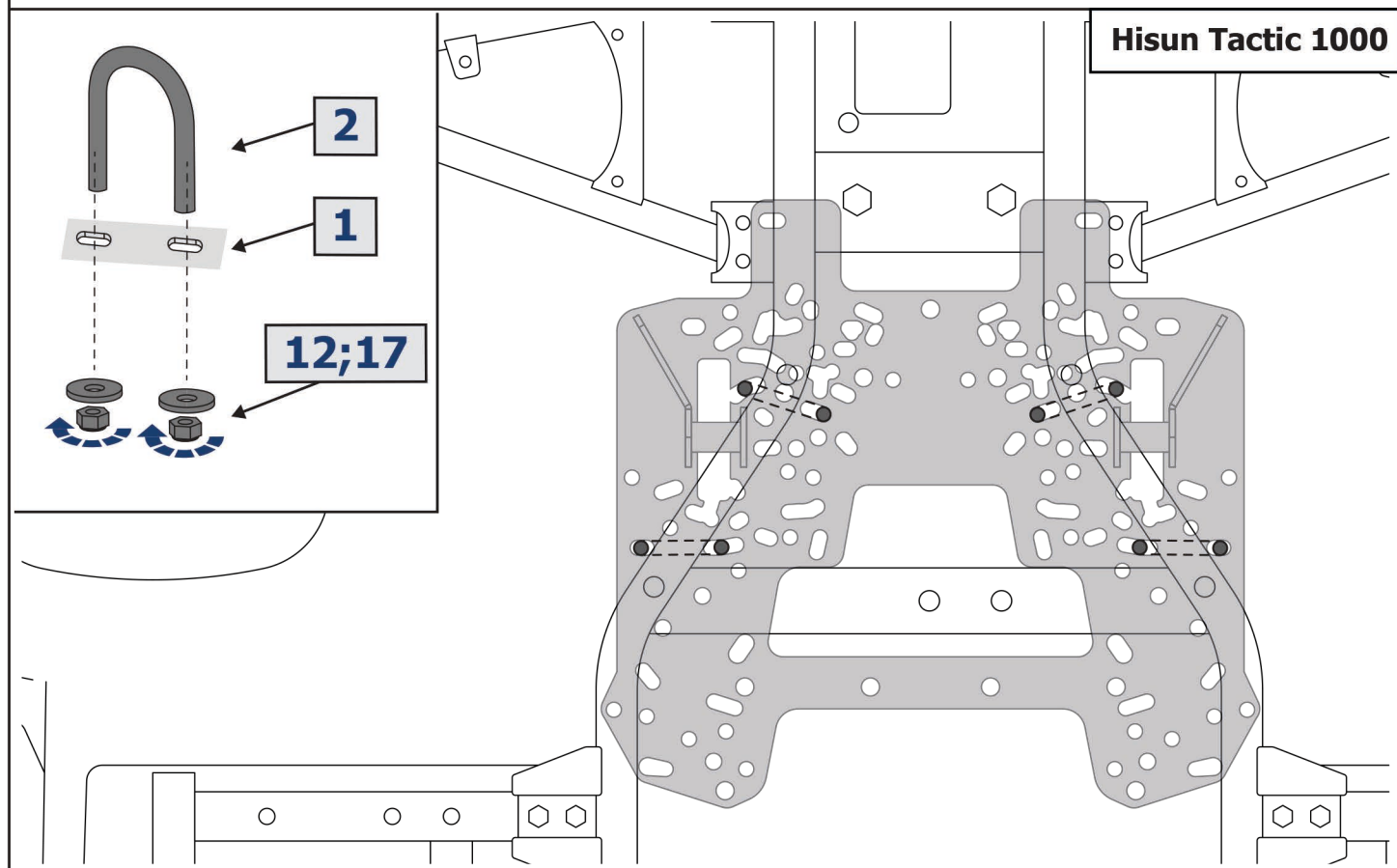
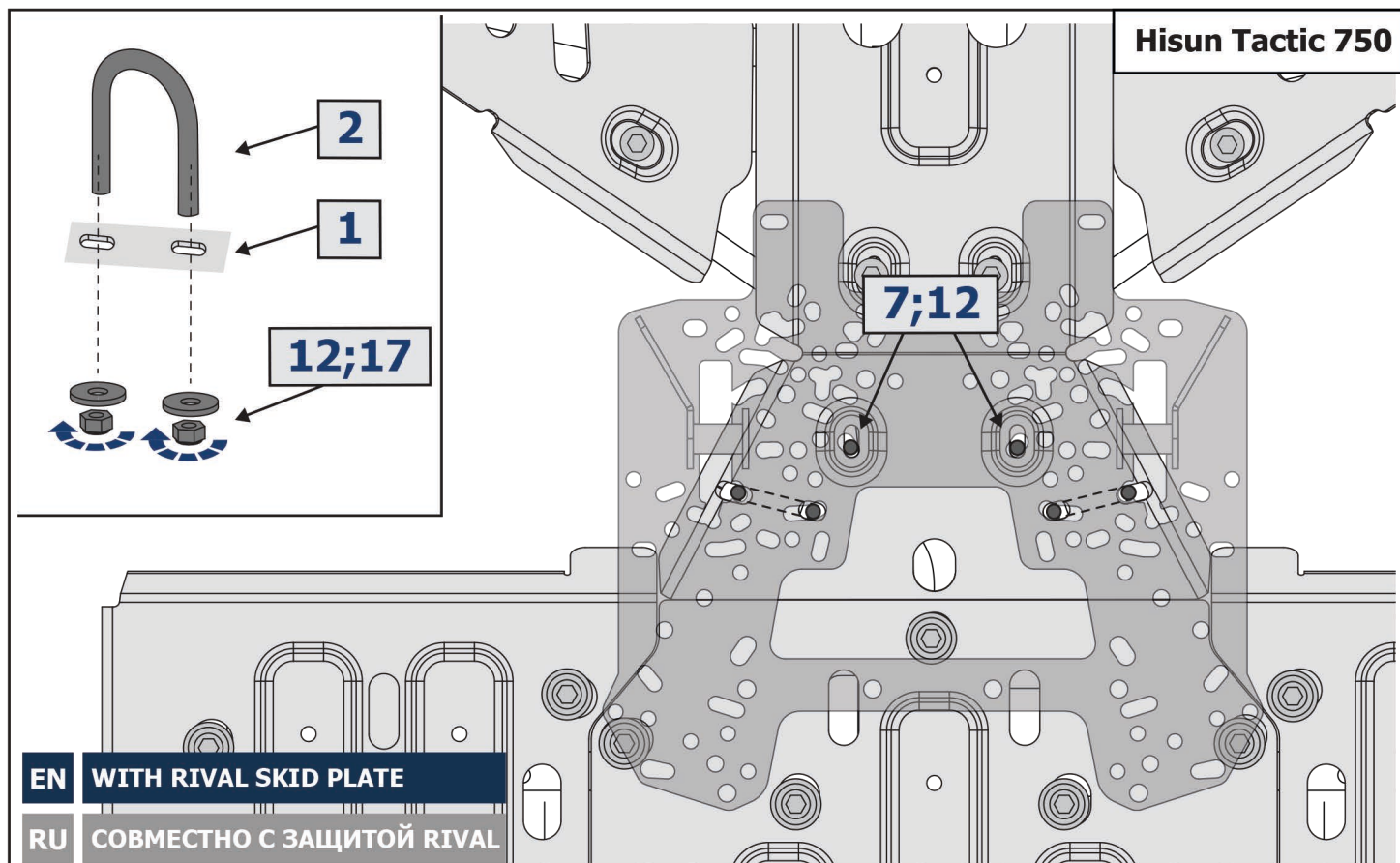

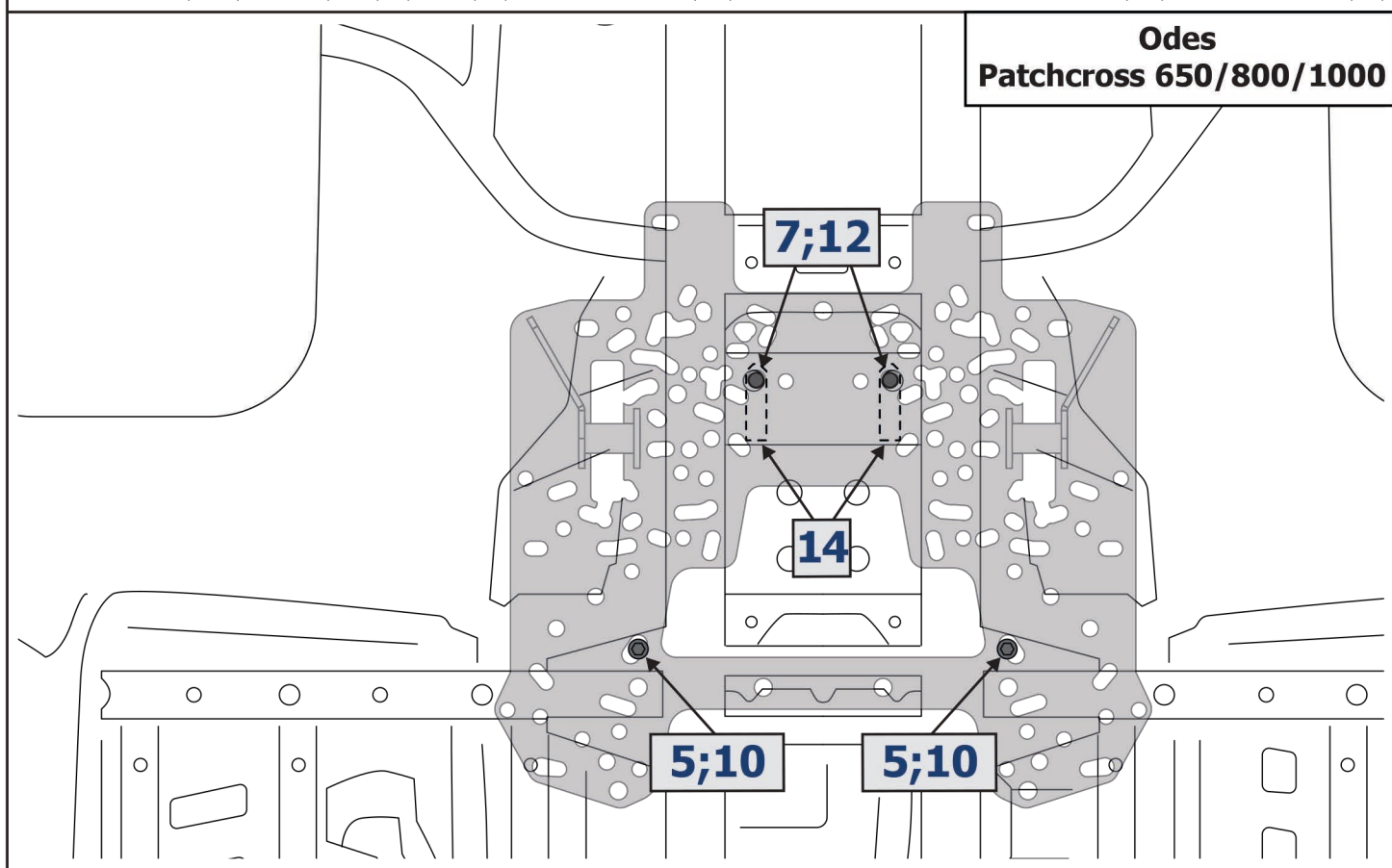
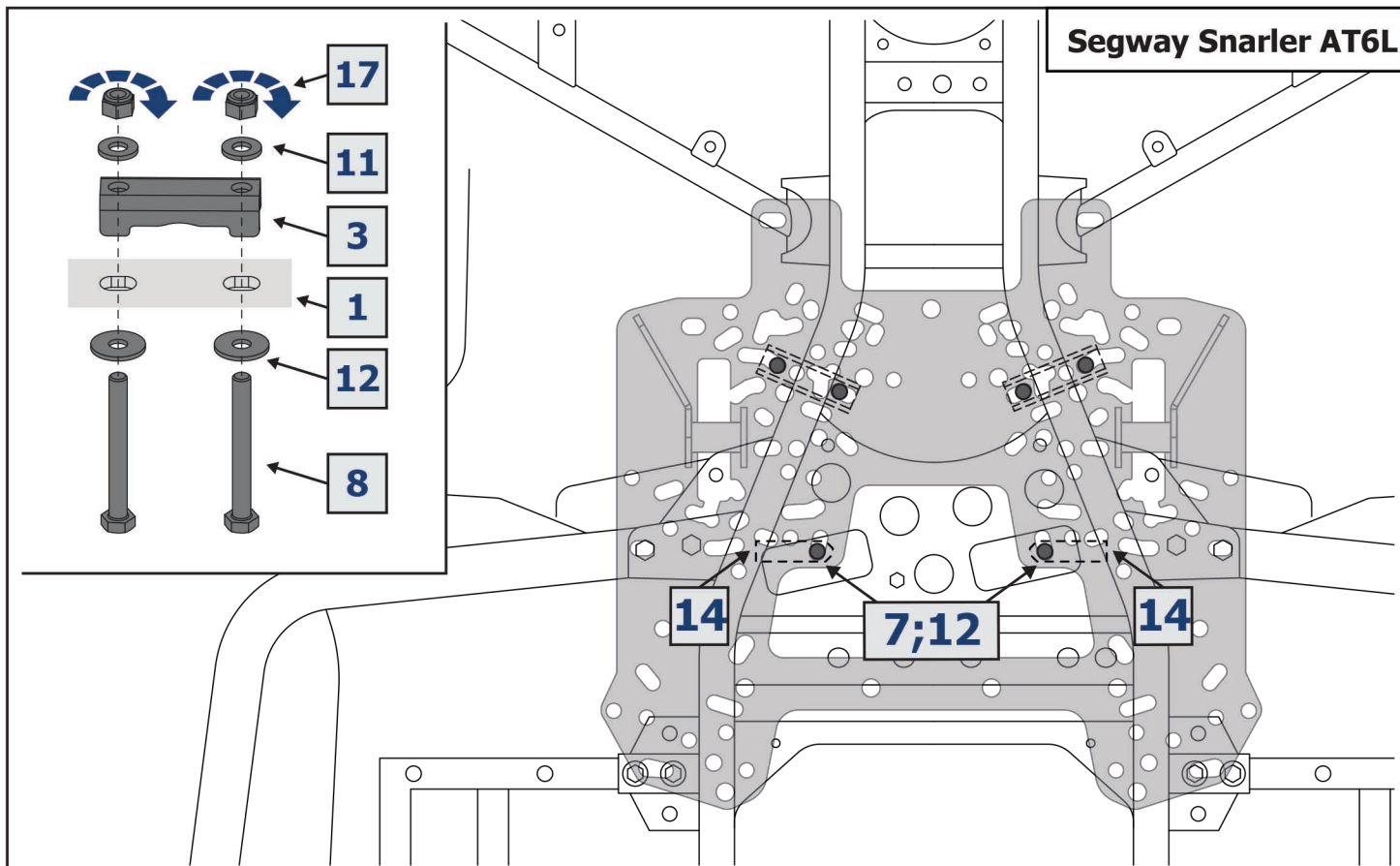

Kymco MXU 700

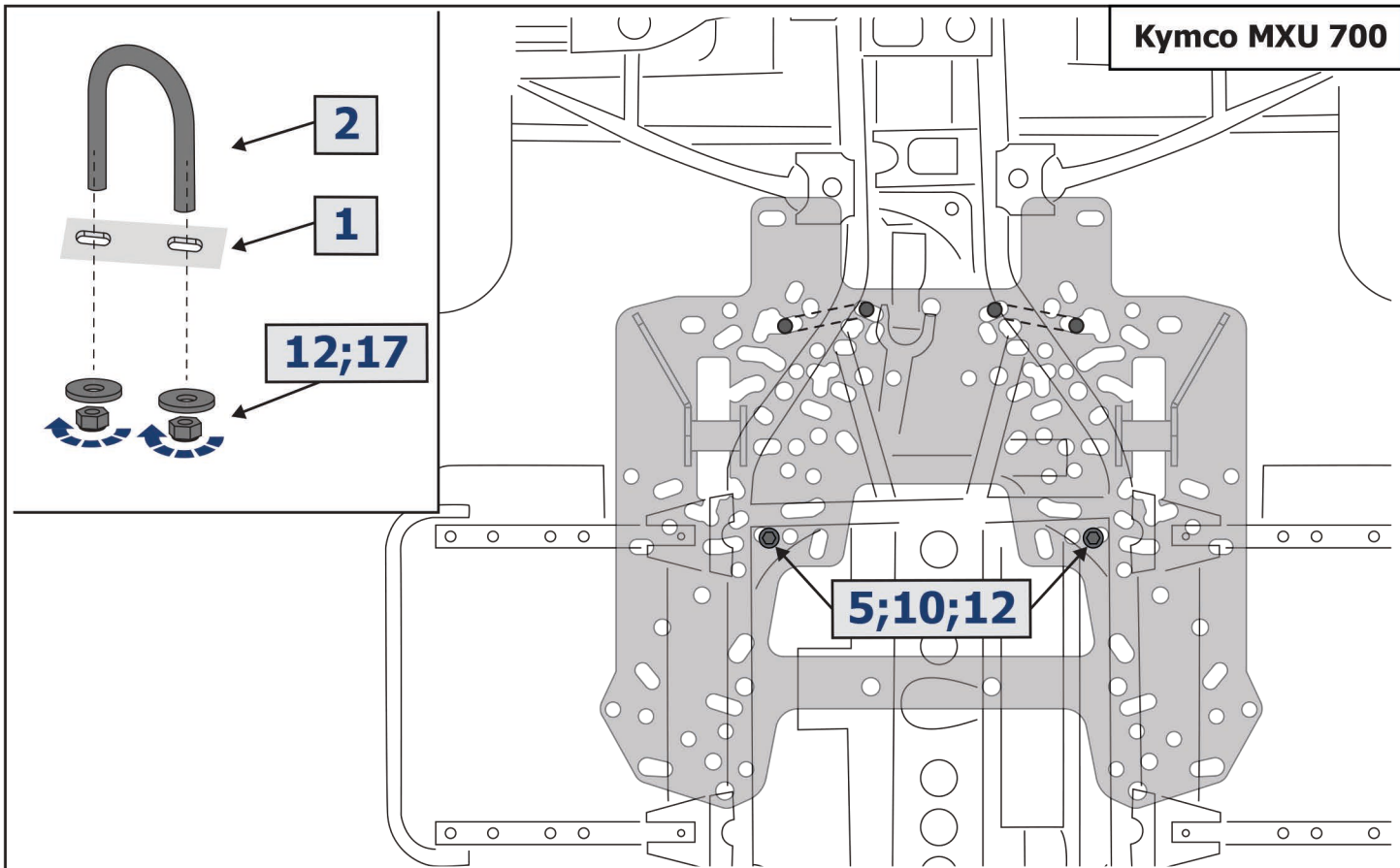

Polaris Sportsman 570

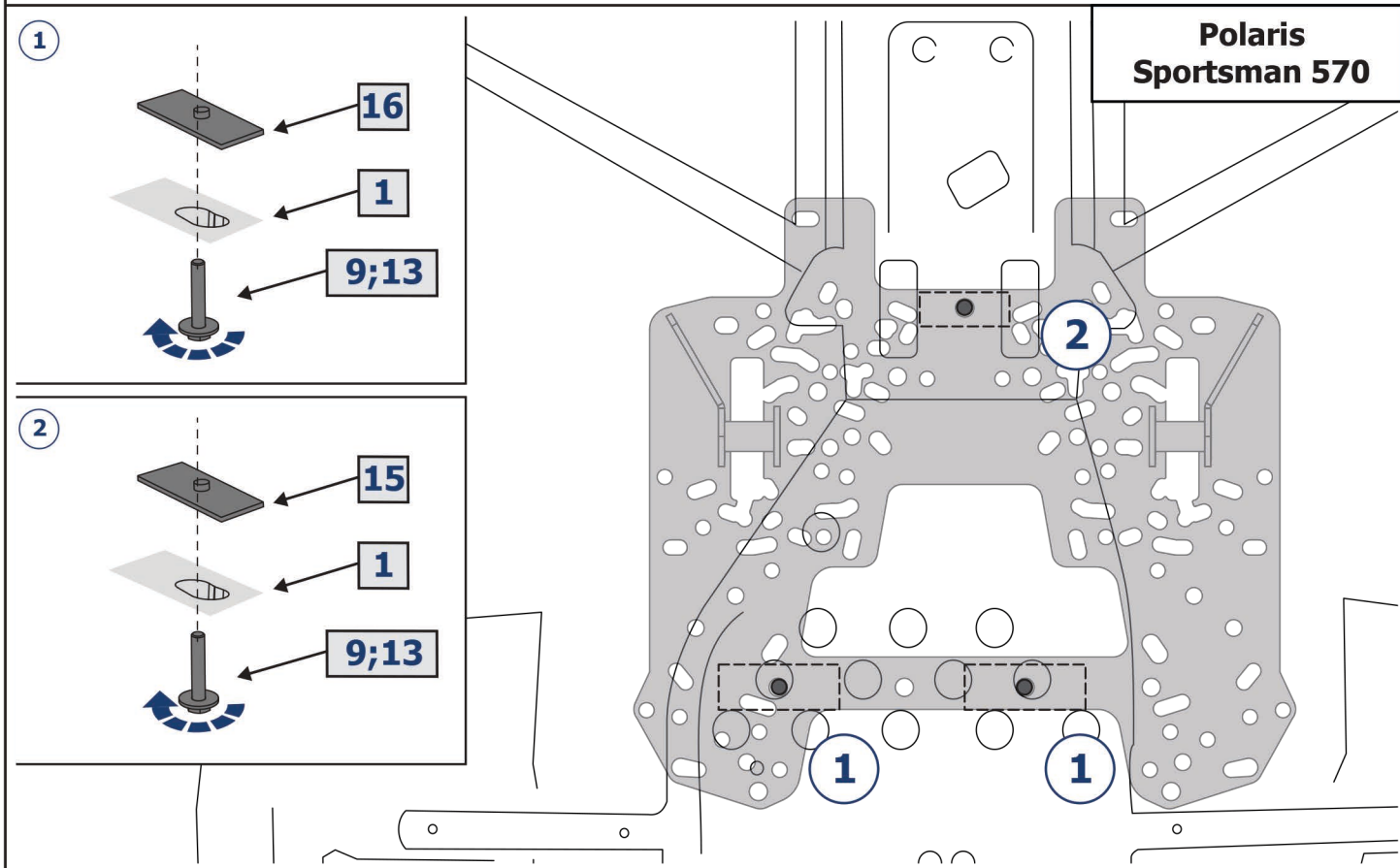

BRP Outlander G2

